

DENON

Ver. 14

Please refer to the
MODIFICATION NOTICE.

SERVICE MANUAL

MODEL	JP	E3	E2	EK	EA	E1C	E1K	CI
PMA-720AE			✓			✓		
PMA-520AE			✓			✓		

INTEGRATED STEREO AMPLIFIER

• For purposes of improvement, specifications and design are subject to change without notice.

• Please use this service manual with referring to the operating instructions without fail.

• Some illustrations using in this service manual are slightly different from the actual set.

DENON

D&M Holdings Inc.

CONTENTS

ABOUT THIS MANUAL	3
What you can do with this manual	3
Using Adobe Reader (Windows version)	4
SAFETY PRECAUTIONS	6
NOTE FOR SCHEMATIC DIAGRAM	7
NOTE FOR PARTS LIST	7
TECHNICAL SPECIFICATIONS	8
DIMENSION	8
DISASSEMBLY	9
1. FRONT PANEL ASSY	10
3. MAIN PCB ASSY.....	11
4. POWER TRANSFORMER	11
ADJUSTMENT	12
TROUBLE SHOOTING	13
1. The power can not be turned on. (Power indication LED does not light.)	13
2. The power turned on, but a sound does not output normally. (Both channels).....	13
BLOCK AND LEVEL DIAGRAM	15
WIRING DIAGRAM	16
PRINTED WIRING BOARDS	17
MAIN	17
FRONT	19
HEADPHONE	19
POWER (PMA-720AE)	20
POWER (PMA-520AE)	20
REMOTE CONTROL	21
FUNCTION.....	21
POWER SW.....	21
VOLUME	21
SCHEMATIC DIAGRAMS (1/2)	22
TONE PART	22
POWER PART	22
FUNCTION SW PART.....	22
VOLUME PART	22
POWER SW PART.....	22
FLASHER INOUT PART	22
MAIN PART	23
EXPLODED VIEW (PMA-720AE)	24
PARTS LIST OF EXPLODED VIEW (PMA-720AE)	25
PACKING VIEW (PMA-720AE)	26
PARTS LIST OF PACKING & ACCESSORIES (PMA-720AE)	26
EXPLODED VIEW (PMA-520AE)	27
PARTS LIST OF EXPLODED VIEW (PMA-520AE)	28
PACKING VIEW (PMA-520AE)	29
PARTS LIST OF PACKING & ACCESSORIES (PMA-520AE)	29
SEMICONDUCTORS	31
1. IC's	31
PARTS LIST OF P.C.B. UNIT	35
FRONT PCB ASSY (PMA-720AE)	35
FRONT PCB ASSY (PMA-520AE)	38
MAIN PCB ASSY (PMA-720AE)	40
MAIN PCB ASSY (PMA-520AE)	46

ABOUT THIS MANUAL

Read the following information before using the service manual.

What you can do with this manual

Search for a Ref. No. (phrase) (Ctrl+Shift+F)

You can use the search function in Acrobat Reader to search for a Ref. No. in schematic diagrams, printed wiring board diagrams, block diagrams, and parts lists.

1. Press **Ctrl+Shift+F** on the keyboard.
 - The Search window appears.

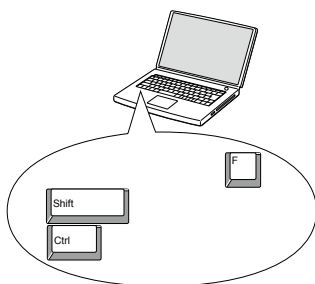

2. Enter the Ref. No. you want to search for in the Search window, and then click the **Search** button.
 - A list of search results appears.

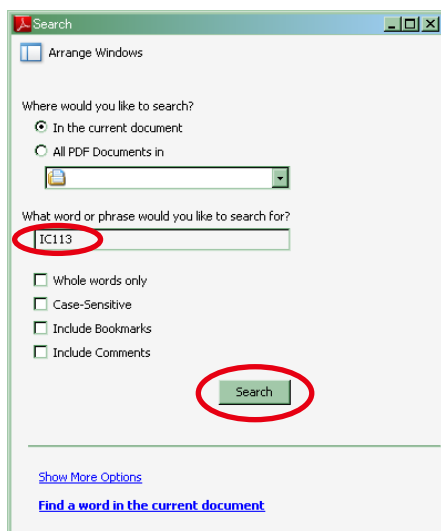

3. Click an item on the list.
 - The screen jumps to the page for that item, and the search phrase is displayed.

Using Adobe Reader (Windows version)

Add notes to this data (Sign)

The Sign function lets you add notes to the data in this manual.
Save the file once you have finished adding notes.

[Example using Adobe Reader X]

On the "View" menu, click "Sign".

- The Sign pane appears.

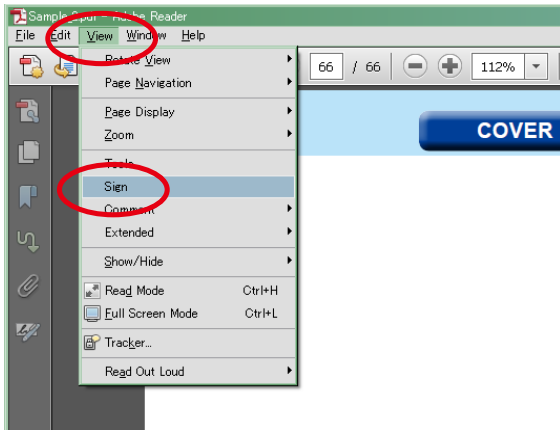

[Example using Adobe Reader 9]

On the "Document" menu, click "Sign".

Magnify schematic / printed wiring board diagrams - 1 (Ctrl+Space, mouse operation)

Press **Ctrl+Space** on the keyboard and drag the mouse to select the area you want to view.

- The selected area is magnified.

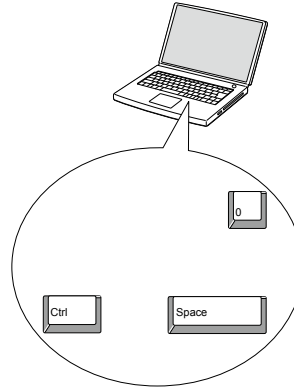

- When you want to move the area shown, hold down **Space** and drag the mouse.

- When you want to show a full page view, press **Ctrl+0** on the keyboard.

Print a magnified part of the manual

The Properties dialog box and functions will vary depending on your printer.

1. Drag the mouse to magnify the part you want to print.
2. On the "File" menu, click "Print".
3. Configure the following settings in the Print dialog box.

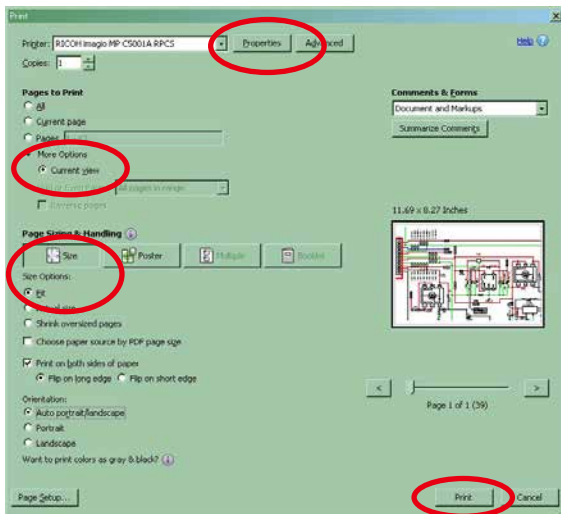

• Properties

Click this button and check that the printer is set to a suitable paper size.

• Page to print

Select the following checkbox.

"More Options" : "Current View"

• Page Sizing & Handling

Select the following checkbox.

"Size" / "Size Options" : "Fit"

4. Click the **Print** button to start printing.

Magnify schematic / printed wiring board diagrams - 2

(Pan & Zoom function)

The Pan & Zoom function lets you see which part of a magnified diagram is being shown in a separate window.

[Example using Adobe Reader X]

On the "View" menu, point to "Zoom", and then click "Pan & Zoom".

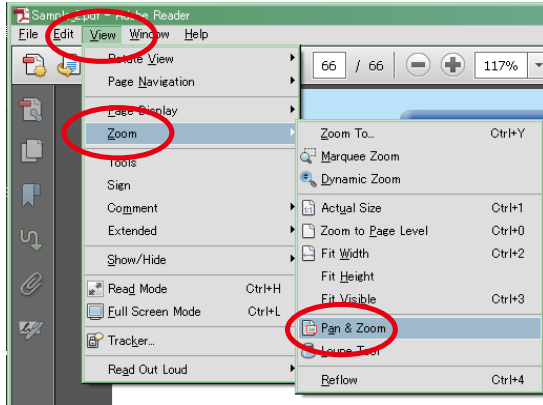

- The Pan & Zoom window appears on the screen.

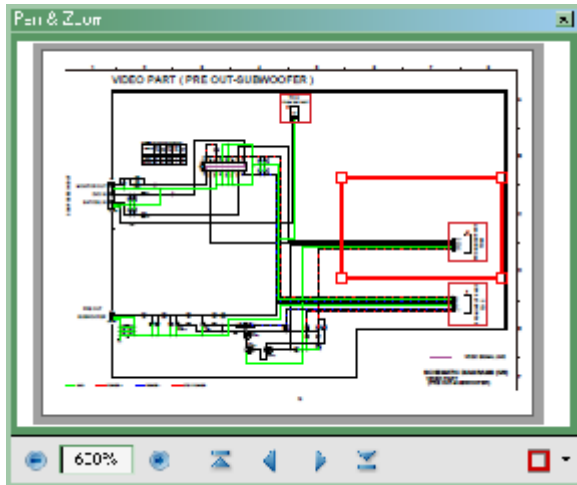

[Example using Adobe Reader 9]

On the "Tools" menu, point to "Select & Zoom", and then click "Pan & Zoom Window".

Magnify schematic / printed wiring board diagrams - 3

(Loupe Tool function)

The Loupe Tool function lets you magnify a specific part of a diagram in a separate window.

[Example using Adobe Reader X]

On the "View" menu, point to "Zoom", and then click "Loupe Tool".

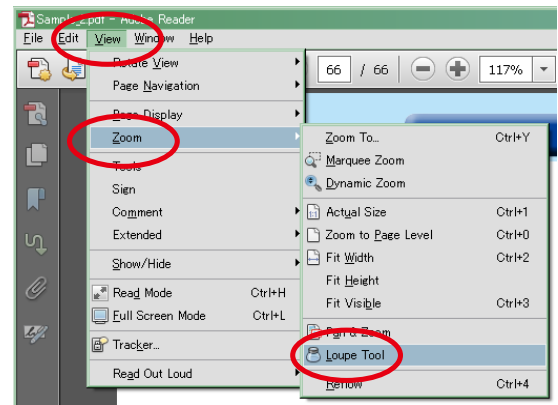

- The Loupe Tool window appears on the screen.

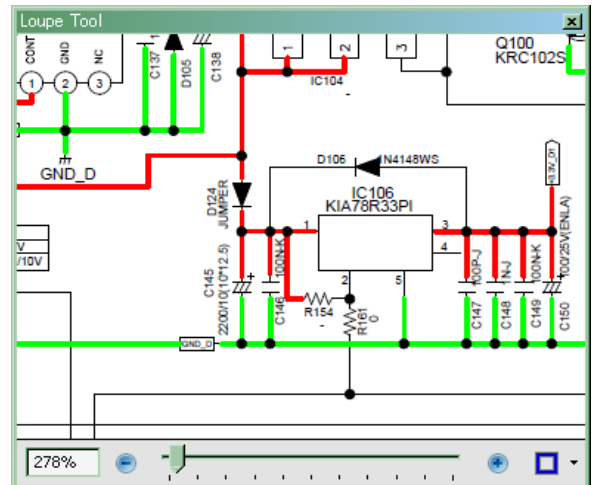

[Example using Adobe Reader 9]

On the "Tools" menu, point to "Select & Zoom", and then click "Loupe Tool Window".

SAFETY PRECAUTIONS

The following items should be checked for continued protection of the customer and the service technician.

LEAKAGE CURRENT CHECK

Before returning the set to the customer, be sure to carry out either (1) a leakage current check or (2) a line to chassis resistance check. If the leakage current exceeds 0.5 milliamps, or if the resistance from chassis to either side of the power cord is less than 460 kohms, the set is defective.

Be sure to test for leakage current with the AC plug in both polarities, in addition, when the set's power is in each state (on, off and standby mode), if applicable.

CAUTION Please heed the following cautions and instructions during servicing and inspection.

⊙ Heed the cautions!

Cautions which are delicate in particular for servicing are labeled on the cabinets, the parts and the chassis, etc. Be sure to heed these cautions and the cautions described in the handling instructions.

⊙ Cautions concerning electric shock!

- (1) An AC voltage is impressed on this set, so if you touch internal metal parts when the set is energized, you may get an electric shock. Avoid getting an electric shock, by using an isolating transformer and wearing gloves when servicing while the set is energized, or by unplugging the power cord when replacing parts, for example.
- (2) There are high voltage parts inside. Handle with extra care when the set is energized.

⊙ Caution concerning disassembly and assembly!

Through great care is taken when parts were manufactured from sheet metal, there may be burrs on the edges of parts. The burrs could cause injury if fingers are moved across them in some rare cases. Wear gloves to protect your hands.

⊙ Use only designated parts!

The set's parts have specific safety properties (fire resistance, voltage resistance, etc.). Be sure to use parts which have the same properties for replacement. The burrs have the same properties. In particular, for the important safety parts that are indicated by the \triangle mark on schematic diagrams and parts lists, be sure to use the designated parts.

⊙ Be sure to mount parts and arrange the wires as they were originally placed!

For safety reasons, some parts use tapes, tubes or other insulating materials, and some parts are mounted away from the surface of printed circuit boards. Care is also taken with the positions of the wires by arranging them and using clamps to keep them away from heating and high voltage parts, so be sure to set everything back as it was originally placed.

⊙ Make a safety check after servicing!

Check that all screws, parts and wires removed or disconnected when servicing have been put back in their original positions, check that no serviced parts have deteriorate the area around. Then make an insulation check on the external metal connectors and between the blades of the power plug, and otherwise check that safety is ensured.

(Insulation check procedure)

Unplug the power cord from the power outlet, disconnect the antenna, plugs, etc., and on the power. Using a 500V insulation resistance tester, check that the insulation resistance value between the inplug and the externally exposed metal parts (antenna terminal, headphones terminal, input terminal, etc.) is 1M Ω or greater. If it is less, the set must be inspected and repaired.

CAUTION Concerning important safety parts

Many of the electric and the structural parts used in the set have special safety properties. In most cases these properties are difficult to distinguish by sight, and the use of replacement parts with higher ratings (rated power and withstand voltage) does not necessarily guarantee that safety performance will be preserved. Parts with safety properties are indicated as shown below on the wiring diagrams and the parts list in this service manual. Be sure to replace them with the parts which have the designated part number.

- (1) Schematic diagrams.....Indicated by the \triangle mark.
- (2) Parts lists.....Indicated by the \triangle mark.

The use of parts other than the designated parts could cause electric shocks, fires or other dangerous situations.

NOTE FOR SCHEMATIC DIAGRAM

WARNING:

Parts indicated by the \triangle mark have critical characteristics. Use ONLY replacement parts recommended by the manufacturer.

CAUTION:

Before returning the set to the customer, be sure to carry out either (1) a leakage current check or (2) a line to chassis resistance check. If the leakage current exceeds 0.5 milliamps, or if the resistance from chassis to either side of the power cord is less than 460 kohms, the set is defective.

WARNING:

DO NOT return the set to the customer unless the problem is identified and remedied.

NOTICE:

ALL RESISTANCE VALUES IN OHM. k=1,000 OHM / M=1,000,000 OHM

ALL CAPACITANCE VALUES ARE EXPRESSED IN MICRO FARAD, UNLESS OTHERWISE INDICATED. P INDICATES MICRO-MICRO FARAD. EACH VOLTAGE AND CURRENT ARE MEASURED AT NO SIGNAL INPUT CONDITION. CIRCUIT AND PARTS ARE SUBJECT TO CHANGE WITHOUT PRIOR NOTICE.

NOTE FOR PARTS LIST

1. Parts indicated by "nsp" on this table cannot be supplied.
2. When ordering a part, make a clear distinction between "1" and "I" (i) to avoid mis-supplying.
3. A part ordered without specifying its part number can not be supplied.
4. Part indicated by "★" mark is not illustrated in the exploded view.
5. General-purpose Carbon Film Resistor in the P.W.Board parts list. (Refer to the Schematic Diagram for those parts.)
6. General-purpose Carbon Chip Resistors are not included are not included in the P.W.Board parts list. (Refer to the Schematic Diagram for those parts.)

WARNING: Parts indicated by the \triangle mark have critical characteristics. Use ONLY replacement parts recommended by the manufacturer.

TECHNICAL SPECIFICATIONS

❑ PMA-720AE

❑ Power amplifier section

Rated output power : 2-channel driving (CD → SP OUT)
 50 W + 50 W (8 Ω, 20 Hz – 20 kHz, T.H.D. 0.07 %)
Dynamic power : 85 W + 85 W (4 Ω, DIN, 1 kHz, T.H.D. 0.7 %)
Total harmonic distortion : 0.01 % (Rated output: –3 dB), 8 Ω, 1 kHz
Output terminals : Speaker A or B: 4 – 16 Ω
 A + B: 8 – 16 Ω
 Suited for headphones/stereo headphones

❑ Pre amplifier section

Equalizer amplifier output (REC OUT terminals) : 150 mV
Input sensitivity/Input impedance :
 PHONO (MM): 2.5 mV/47 kΩ
 CD, TUNER, AUX, Network, RECORDER:
 120 mV / 30 kΩ (SOURCE DIRECT OFF)
 120 mV / 16 kΩ (SOURCE DIRECT ON)
RIAA deviation : PHONO (MM): 20 Hz – 20 kHz±0.5 dB

❑ Overall performance

S/N (IHF-A weight) : PHONO (MM): 86 dB
 (With input terminals short-circuited, 5 mV input signal)
 CD, TUNER, AUX, Network, RECORDER:
 107 dB (input terminals short-circuited)
Tone control : BASS: 100 Hz±8 dB
 TREBLE: 10 kHz±8 dB
Loudness: 100 Hz: +6 dB, 10 kHz: +6 dB

❑ General

Power supply : AC 230 V, 50/60 Hz
Power consumption : 200 W
Power consumption in standby mode : 0.3 W
Power outlets : 3 switched outlets, total capacity 100 W (0.43 A)

❑ PMA-520AE

❑ Power amplifier section

Rated output power : 2-channel driving (CD → SP OUT)
 45 W + 45 W (8 Ω, 20 Hz – 20 kHz, T.H.D. 0.07 %)
Dynamic power : 70 W + 70 W (4 Ω, DIN, 1 kHz, T.H.D. 0.7 %)
Total harmonic distortion : 0.02 % (Rated output: –3 dB), 8 Ω, 1 kHz
Output terminals : Speaker: 4 – 16 Ω
 Suited for headphones/stereo headphones

❑ Pre amplifier section

Equalizer amplifier output (REC OUT terminals) : 150 mV
Input sensitivity/Input impedance :
 PHONO (MM): 2.5 mV/47 kΩ
 CD, TUNER, AUX, Network, RECORDER:
 120 mV / 30 kΩ (SOURCE DIRECT OFF)
 120 mV / 16 kΩ (SOURCE DIRECT ON)
RIAA deviation : PHONO (MM): 20 Hz – 20 kHz±0.5 dB

❑ Overall performance

S/N (IHF-A weight) : PHONO (MM): 84 dB
 (With input terminals short-circuited, 5 mV input signal)
 CD, TUNER, AUX, Network, RECORDER:
 105 dB (input terminals short-circuited)
Tone control : BASS: 100 Hz±8 dB
 TREBLE: 10 kHz±8 dB
Loudness: 100 Hz: +6 dB, 10 kHz: +6 dB

❑ General

Power supply : AC 230 V, 50/60 Hz
Power consumption : 185 W
Power consumption in standby mode : 0.3 W
Power outlets : 1 switched outlets, total capacity 100 W (0.43 A)

DIMENSION

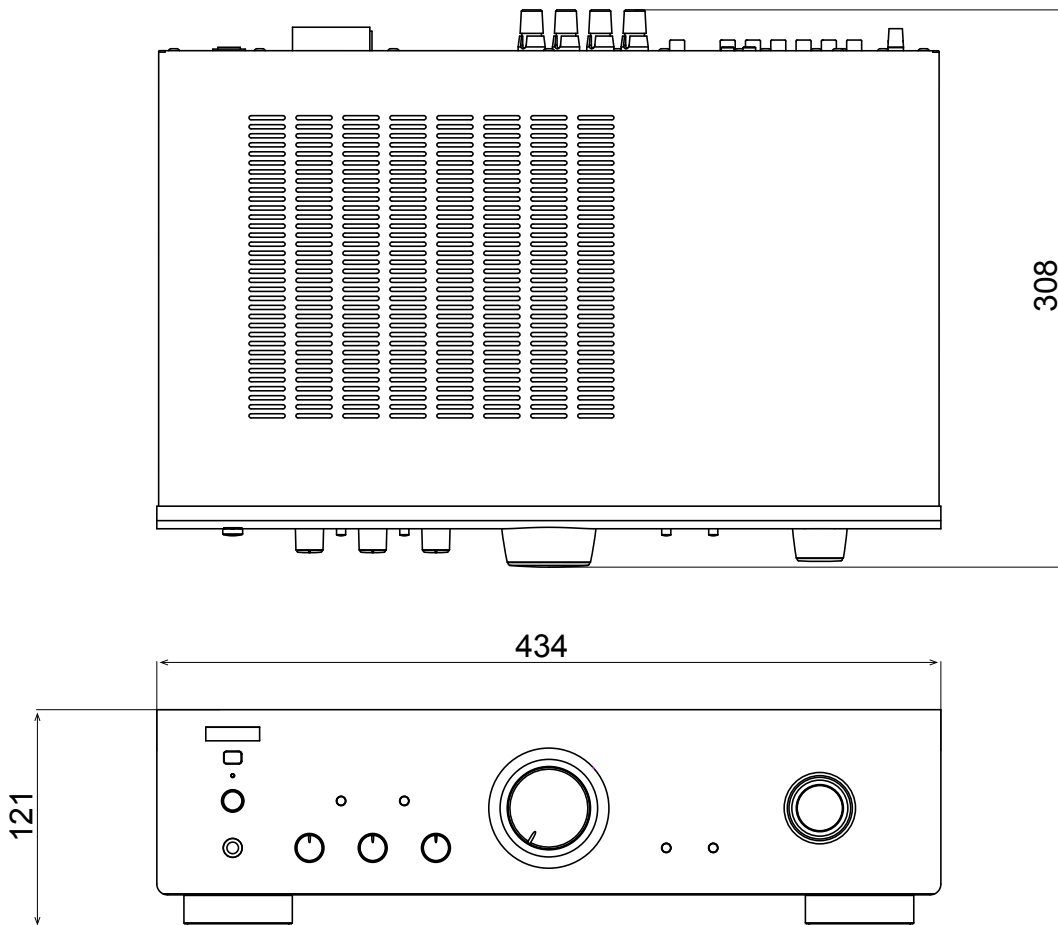

Weight : 7.1kg (PMA-720AE)
 6.8kg (PMA-520AE)

DISASSEMBLY

- Disassemble in order of the arrow in the following figure.
 - In the case of the re-assembly, assemble it in order of the reverse of the following flow.
 - In the case of the reassembling, observe "Caution concerning disassembly and assembly!".
 - If wire bundles are untied or moved to perform adjustment or replace parts etc., be sure to rearrange them neatly as they were originally bundled or placed afterward.
- Otherwise, incorrect arrangement can be a cause of noise generation.

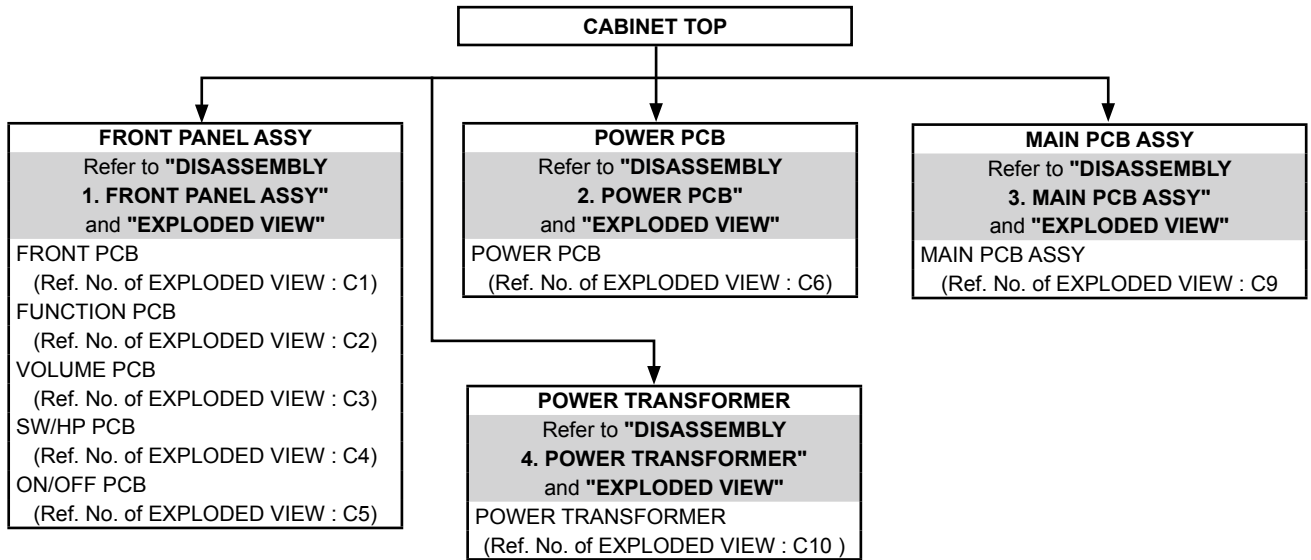

About the photos used for "descriptions of the DISASSEMBLY" section

- The shooting direction of each photograph used herein is indicated on the left side of the respective photograph as "Shooting direction: ***". (** : A,B,C,D)
- Refer to the diagram below about the shooting direction of each photograph.
- Photographs with no shooting direction indicated were taken from the top of the set.
- The photograph is PMA-520AEE2 model.

The viewpoint of each photograph (Shooting direction)

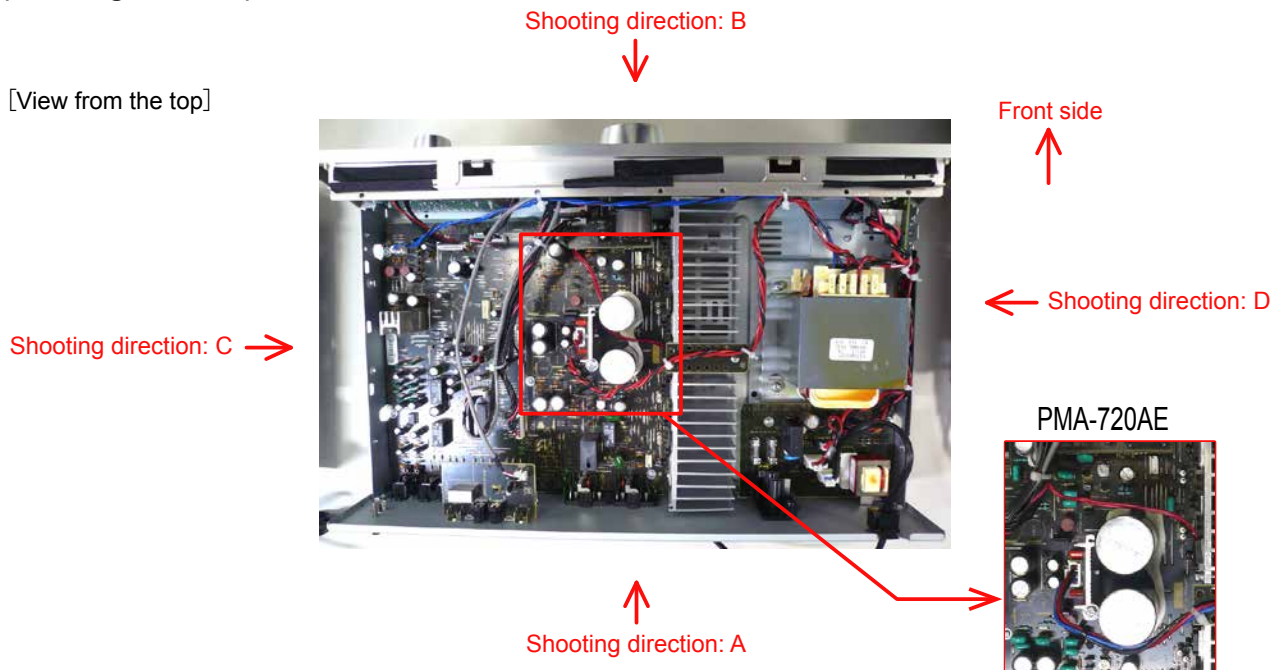

1. FRONT PANEL ASSY

Proceeding : **TOP CABINET** → **FRONT PANEL ASSY**

(1) Remove the screws.

View from the bottom

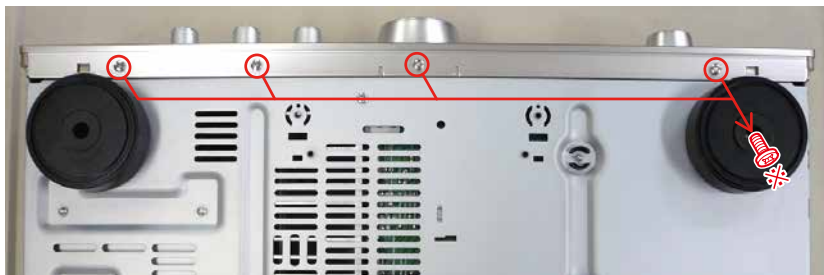

(2) Cut the wire clamp bands.

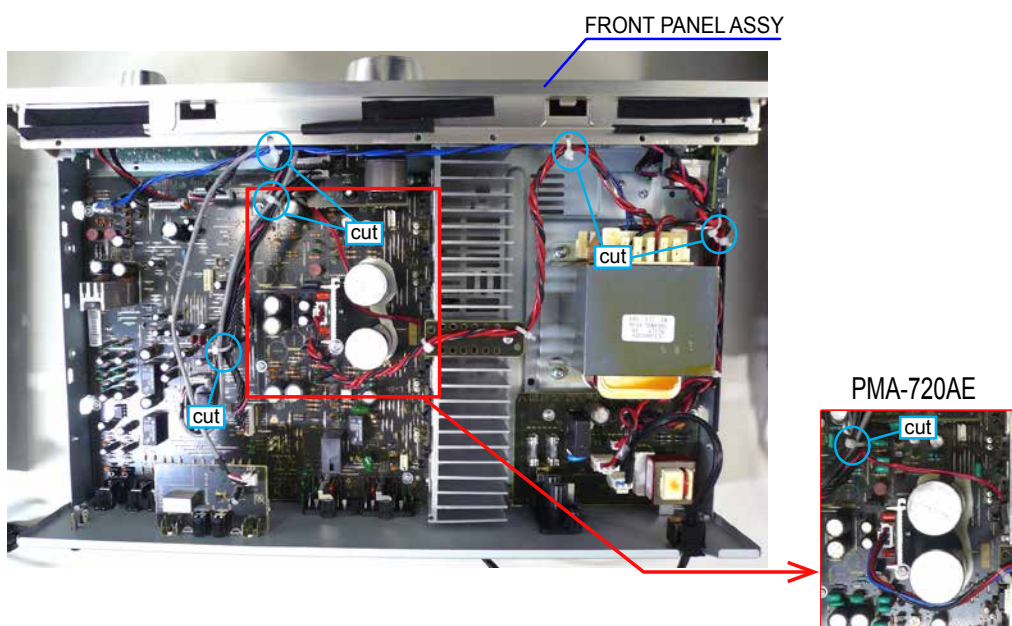

(3) Disconnect the connector wires, then remove the screws.

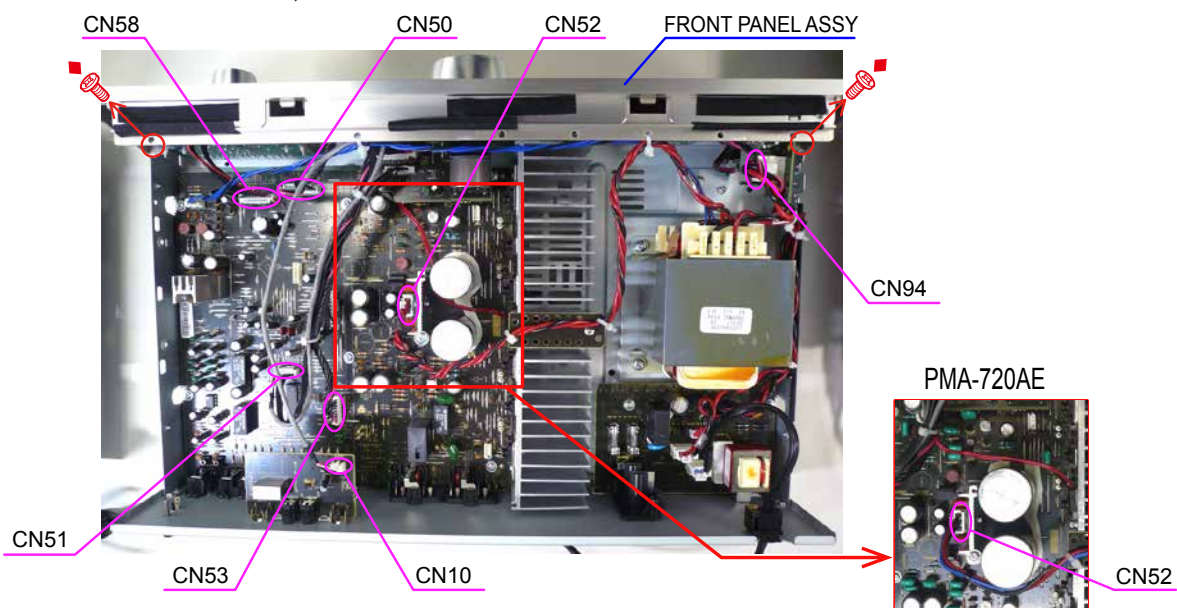

Please refer to "EXPLODED VIEW" for the disassembly method of each PCB included in FRONT PANEL ASSY.

2. POWER PCB

Proceeding : **TOP CABINET** → **POWER PCB**

Please refer to "EXPLODED VIEW" for the disassembly method of POWER PCB.

3. MAIN PCB ASSY

Proceeding : **TOP CABINET** → **MAIN PCB ASSY**

Please refer to "EXPLODED VIEW" for the disassembly method of MAIN PCB ASSY.

4. POWER TRANSFORMER

Proceeding : **TOP CABINET** → **POWER TRANSFORMER**

Please refer to "EXPLODED VIEW" for the disassembly method of POWER TRANSFORMER.

ADJUSTMENT

Adjusting Idling Current

Required measurement equipment: DC Voltmeter

1. Preparation

- (1) Avoid direct blow from an air conditioner or an electric fan and humidity should be moderate, and place the set at normal usage environment.
Temperature should be at 15 °C ~ 30 °C (59 °F ~ 86 °F).
- (2) Presetting
 - POWER (Power source switch) OFF
 - VOLUME (Volume control) ∞ min.
 - SPEAKER (Speaker terminal) No load
(Do not connect speaker, dummy resistor, etc.)

2. Adjustment

- (1) Remove top cover. And then connect DC Voltmeter to the test points CN31 and CN32 of CUP12196B Main PCB.
- (2) Connect power cord to AC wall outlet, and turn POWER switch "ON".
- (3) Right after power on, adjust VR31 and VR32 so that the DC voltmeter reads 10 ± 1 mV.
- (4) Then after 2 minutes warm up adjust VR31 and VR32 so that the DC voltmeter reads 10 ± 1 mV.
- (5) And after 10 minutes warm up adjust VR31 and VR32 so that the DC voltmeter reads 10 ± 0.5 mV.

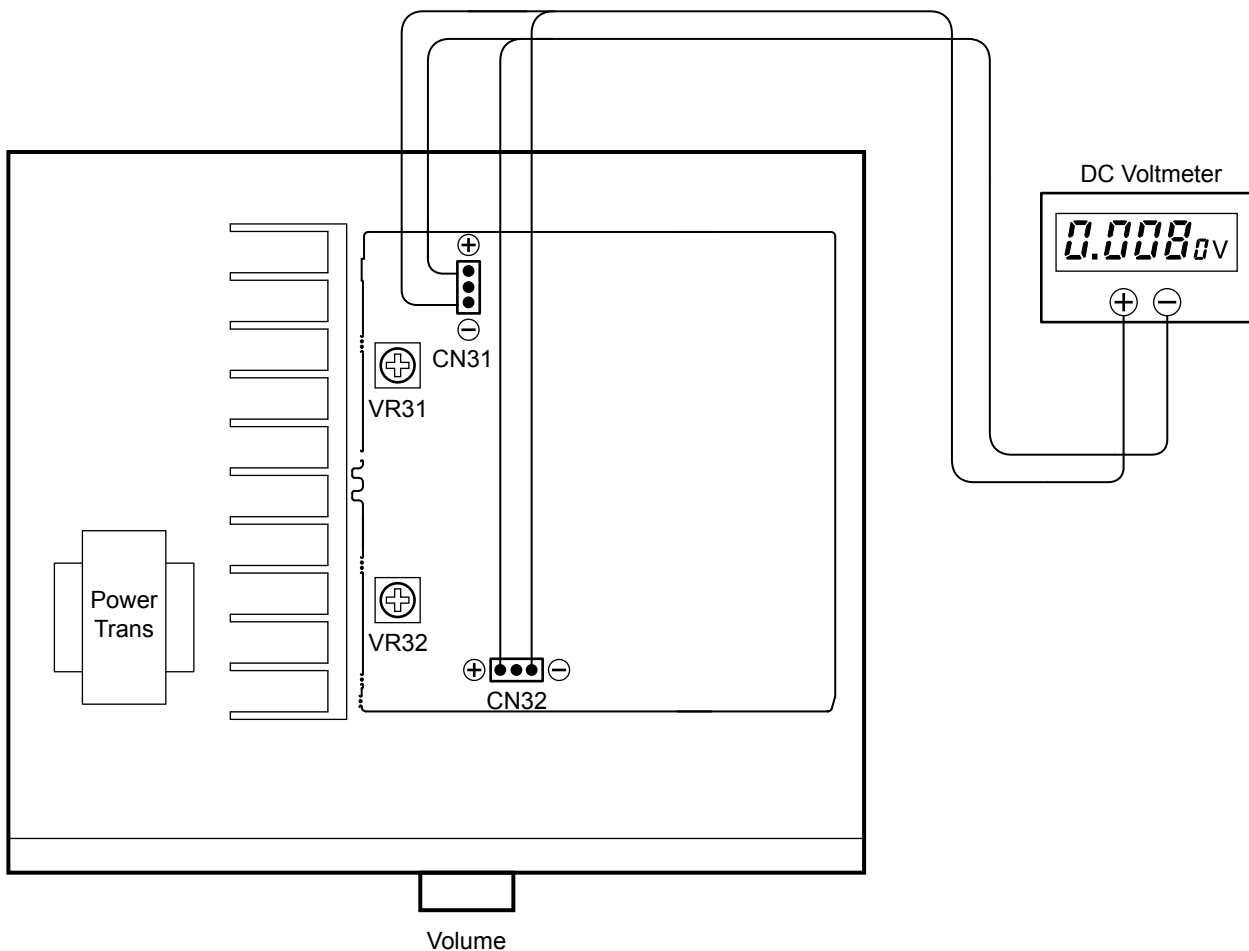

TROUBLE SHOOTING

1. The power can not be turned on. (Power indication LED does not light.)

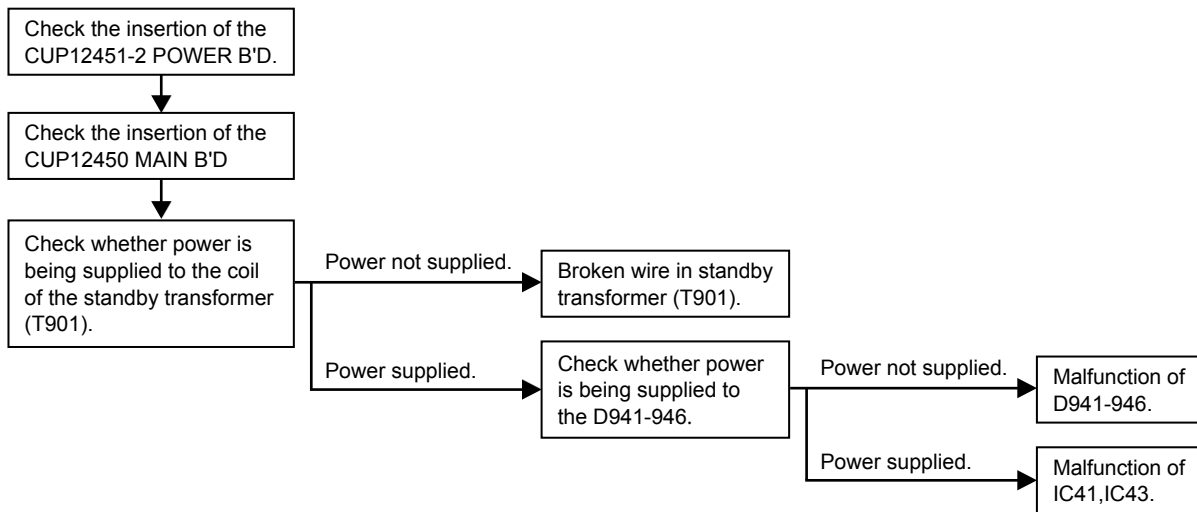

2. The power turned on, but a sound does not output normally. (Both channels)

2.1. Set remains in standby mode.

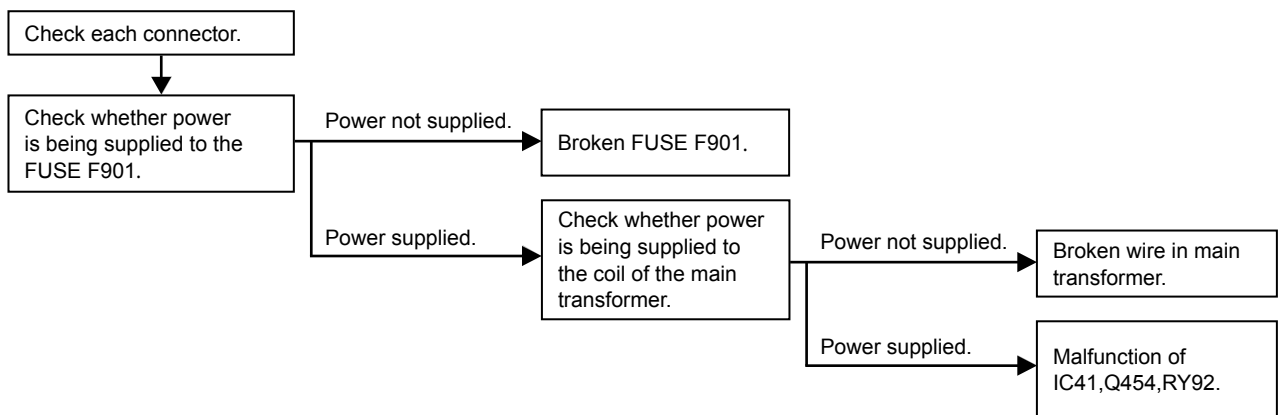

2.2. Power indicator LED remains flashing red and muting mode is not canceled (protection mode is set).

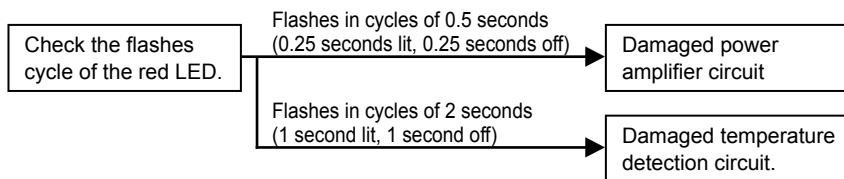

2.3. Set operates, but then power indicator LED flashes red (protection mode is set).

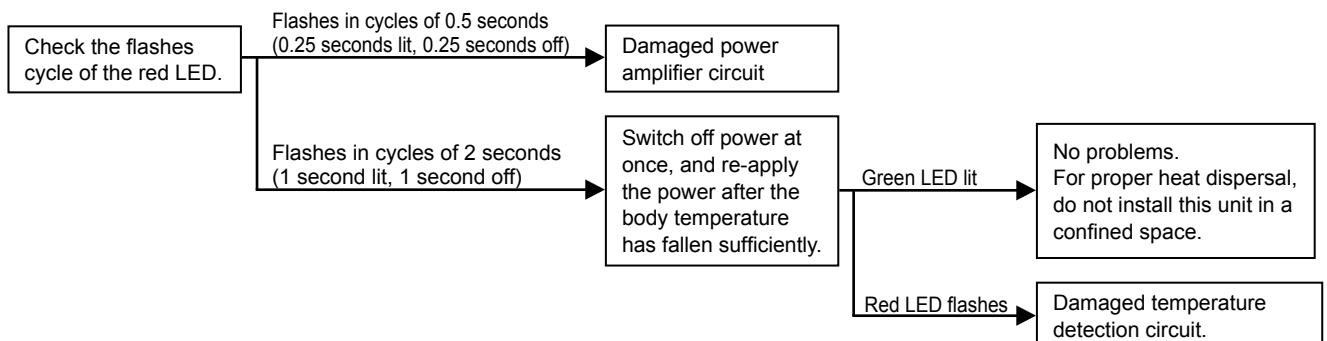

BLOCK AND LEVEL DIAGRAM

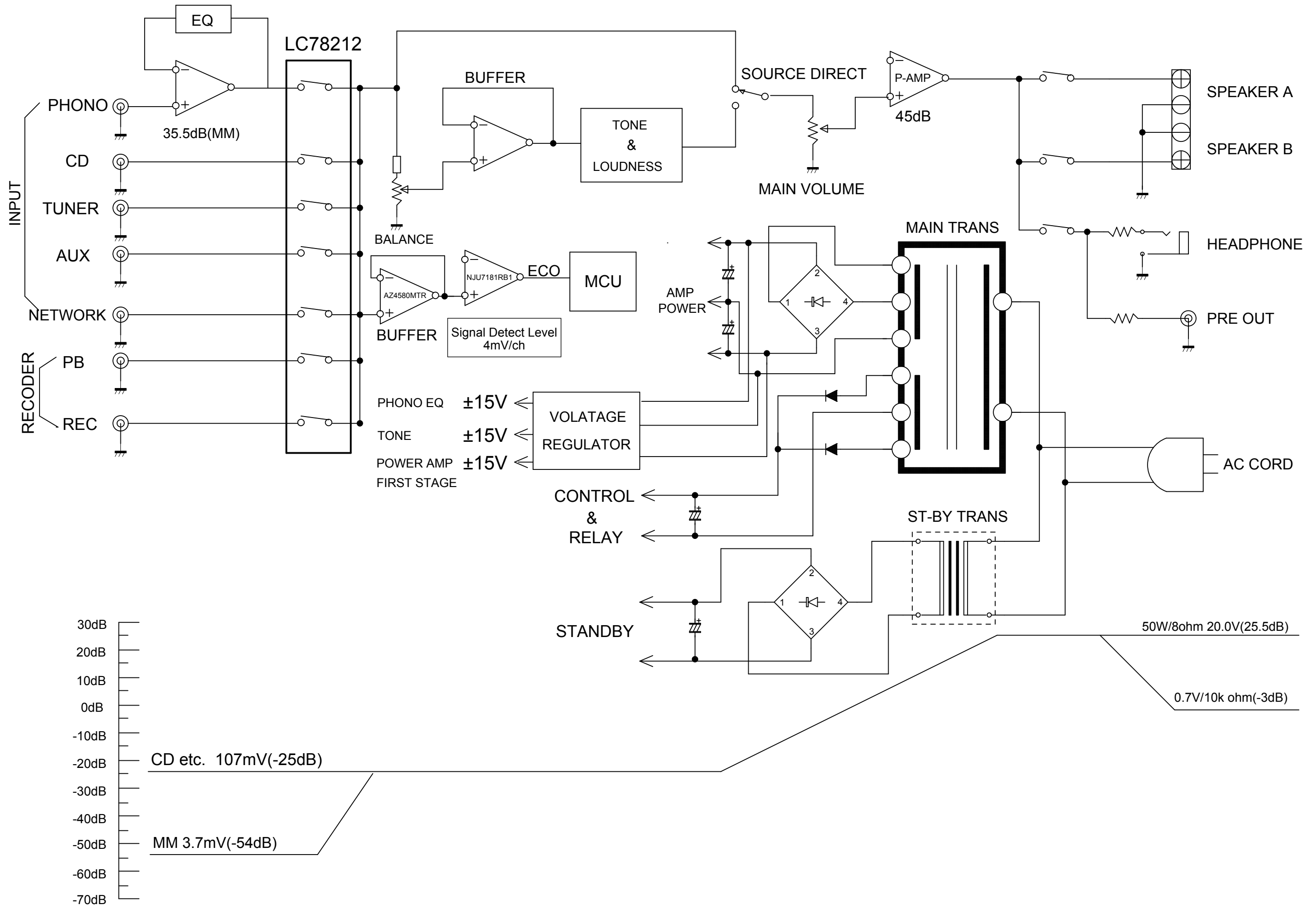

WIRING DIAGRAM

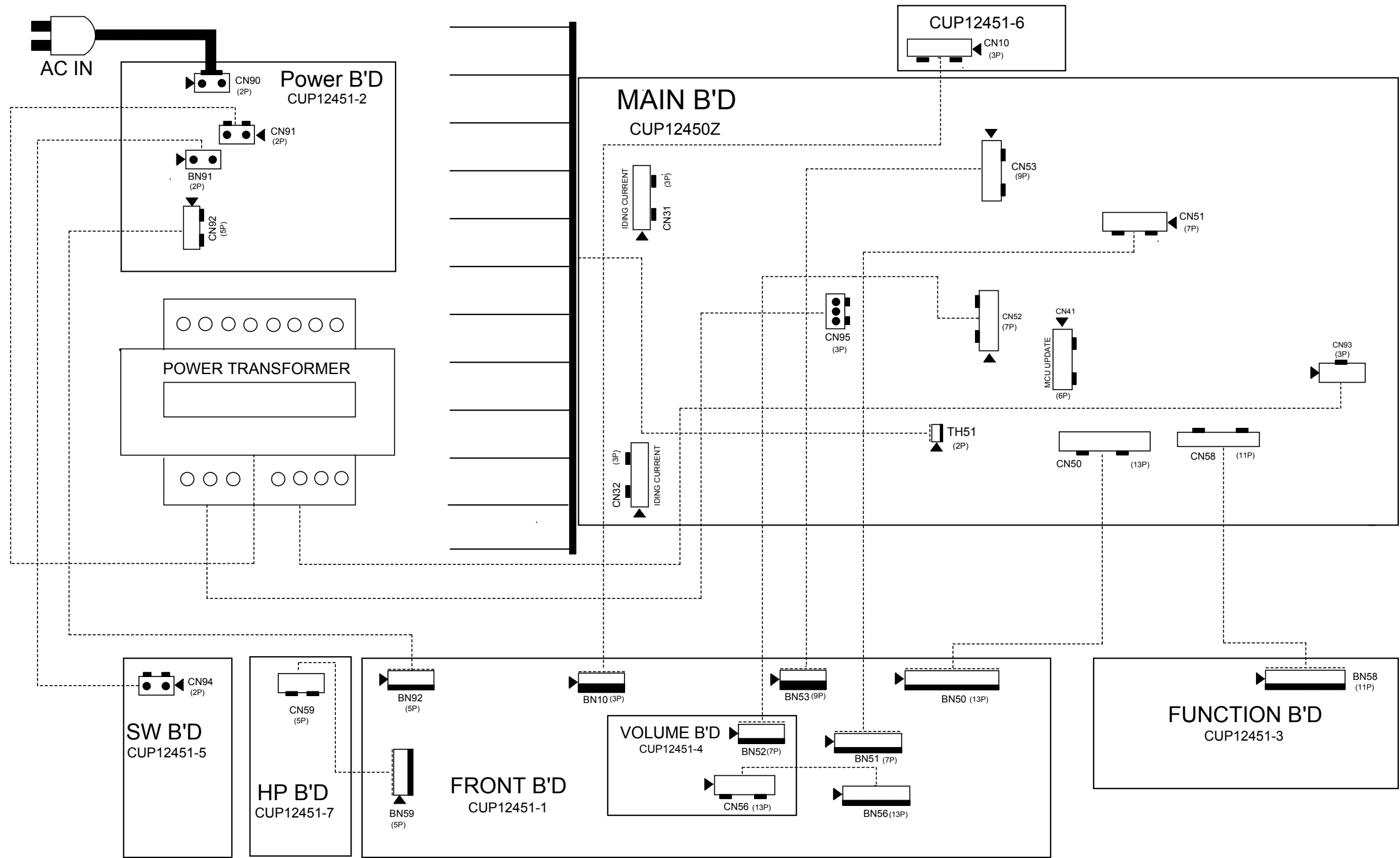

PRINTED WIRING BOARDS

1 2 3 4 5 6 7 8 9 10 11 12 13 14 15 16 17 18

MAIN (COMPONENT SIDE)

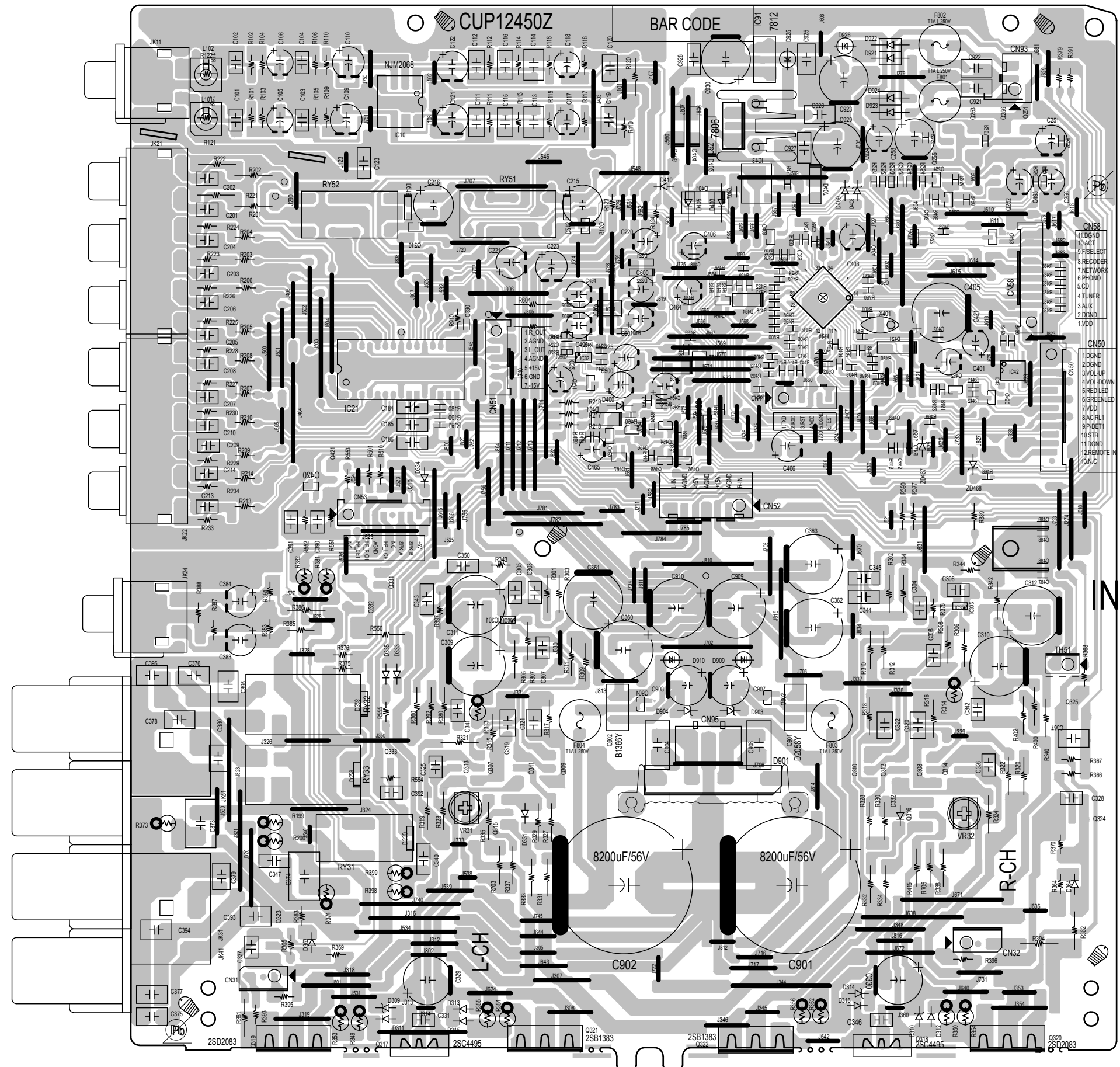

鉛フリー半田
半田付けには、鉛フリー半田 (Sn-Ag-Cu) を使用してください。

Lead-free Solder
When soldering, use the Lead-free Solder (Sn-Ag-Cu).

1 2 3 4 5 6 7 8 9 10 11 12 13 14 15 16 17 18

MAIN
(FOIL SIDE)

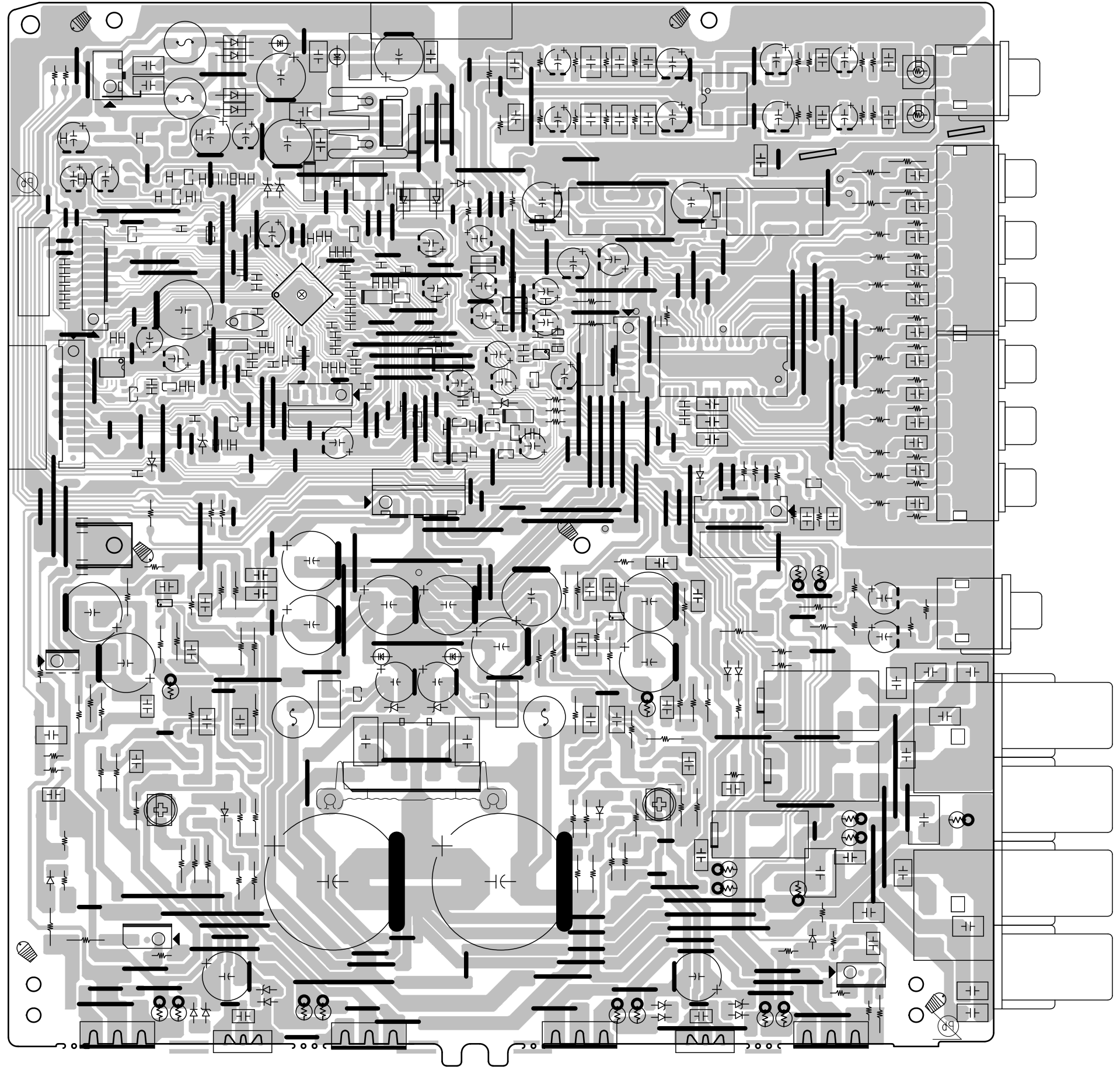

A
B
C
D
E
F
G
H
I
J
K
L
M

鉛フリー半田
半田付けには、鉛フリー半田 (Sn-Ag-Cu) を使用してください。

Lead-free Solder
When soldering, use the Lead-free Solder (Sn-Ag-Cu).

**FRONT
(COMPONENT SIDE)**

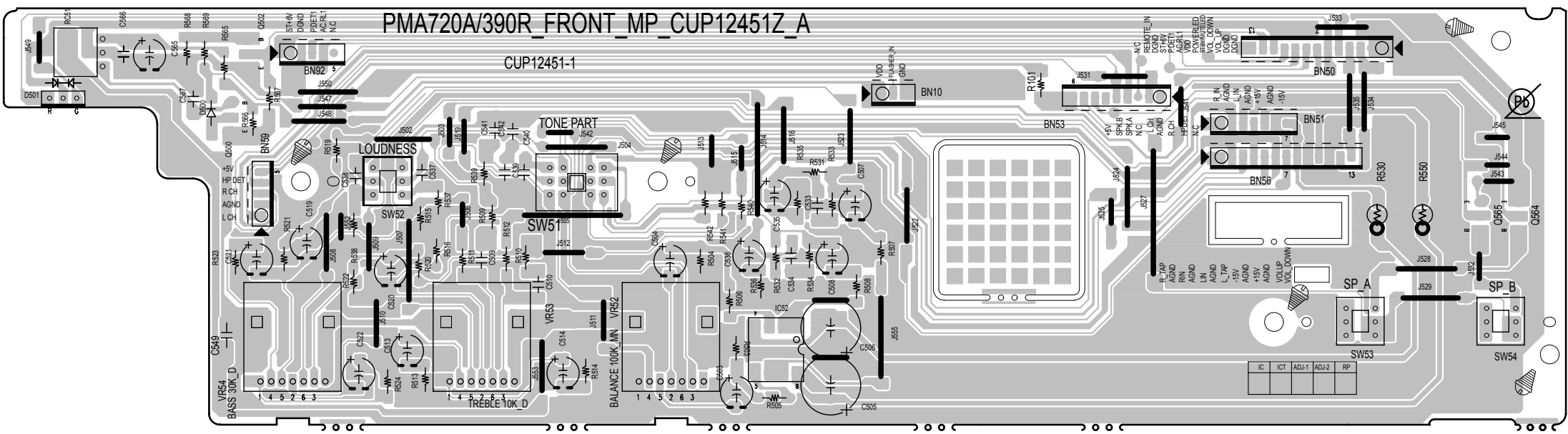

**HEADPHONE
(COMPONENT SIDE)**

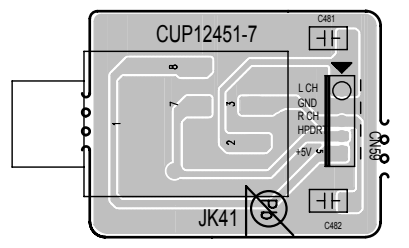

**FRONT
(FOIL SIDE)**

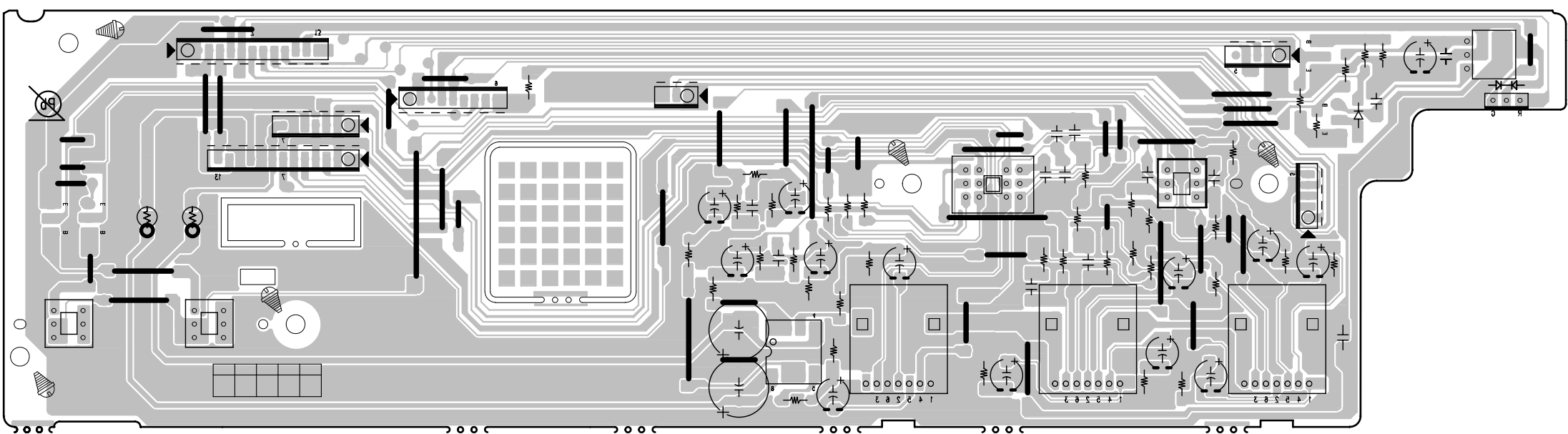

**HEADPHONE
(FOIL SIDE)**

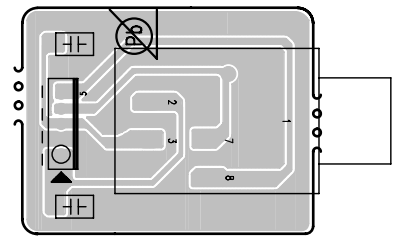

鉛フリー半田
半田付けには、鉛フリー半田 (Sn-Ag-Cu) を使用してください。

Lead-free Solder
When soldering, use the Lead-free Solder (Sn-Ag-Cu).

A
B
C
D
E
F
G
H
I
J
K
L
M

**POWER (PMA-720AE)
(COMPONENT SIDE)**

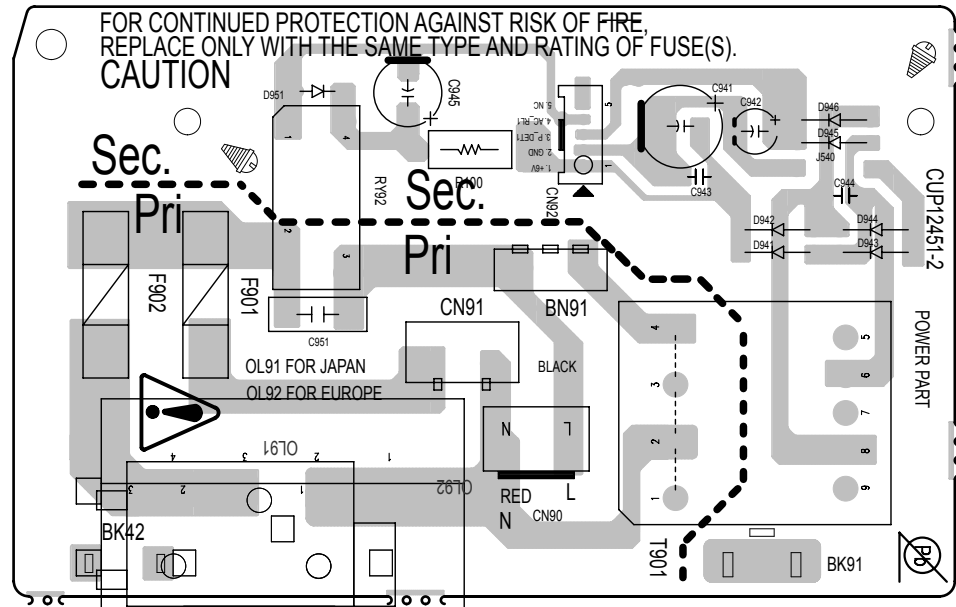

**POWER (PMA-720AE)
(FOIL SIDE)**

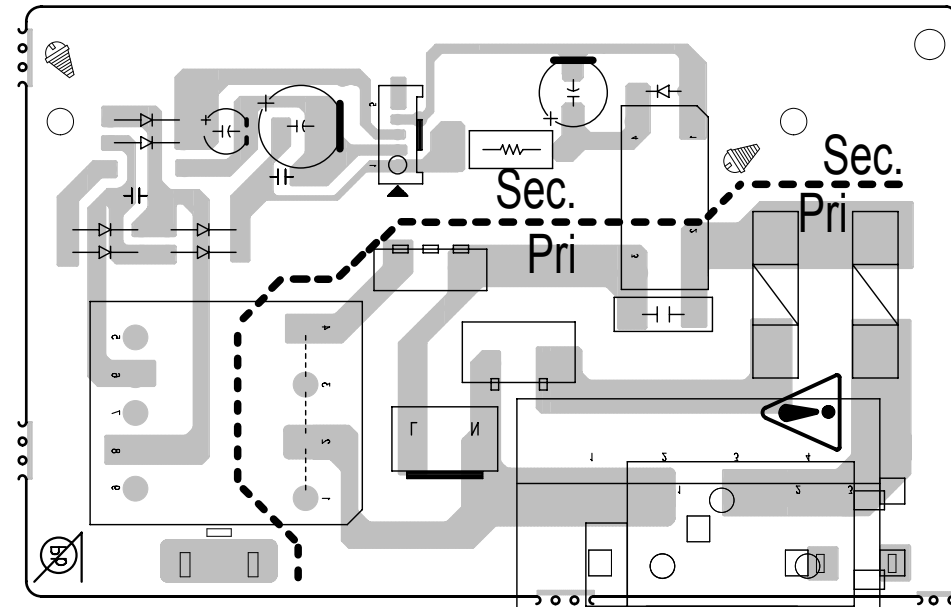

**POWER (PMA-520AE)
(COMPONENT SIDE)**

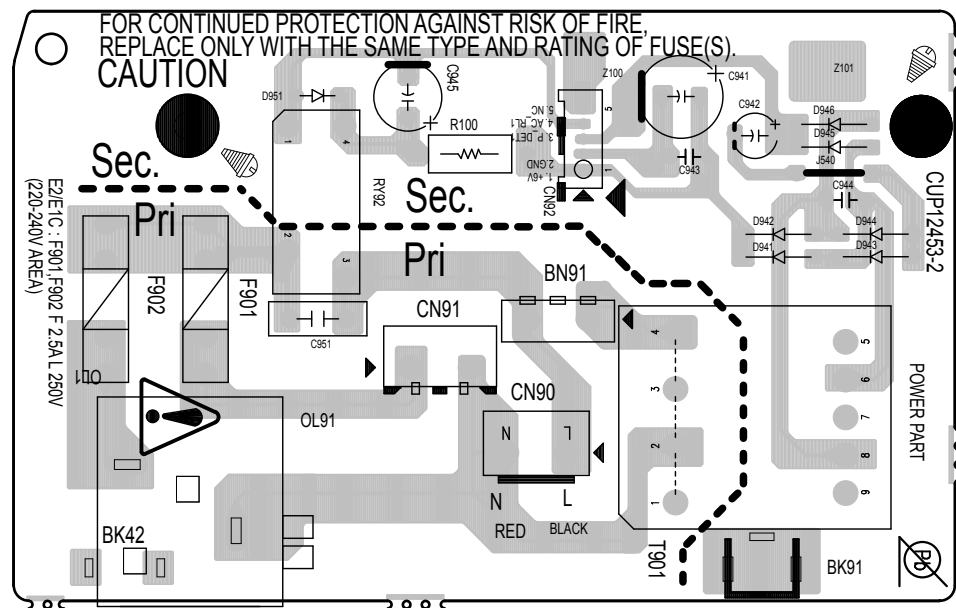

**POWER (PMA-520AE)
(FOIL SIDE)**

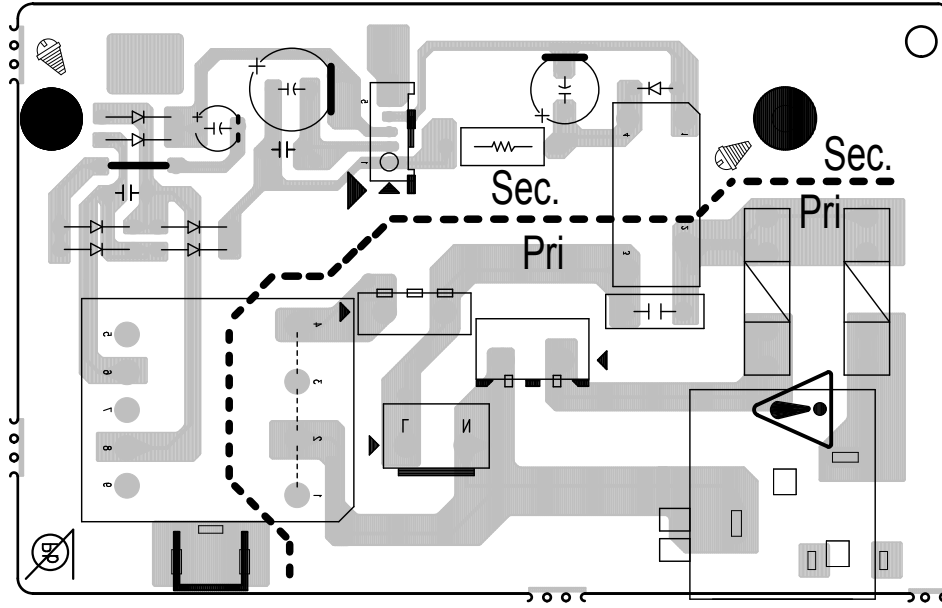

鉛フリー半田
半田付けには、鉛フリー半田 (Sn-Ag-Cu) を使用してください。

Lead-free Solder
When soldering, use the Lead-free Solder (Sn-Ag-Cu).

A
B
C
D
E
F
G
H
I
J
K
L
M

**REMOTE CONTROL
(COMPONENT SIDE)**

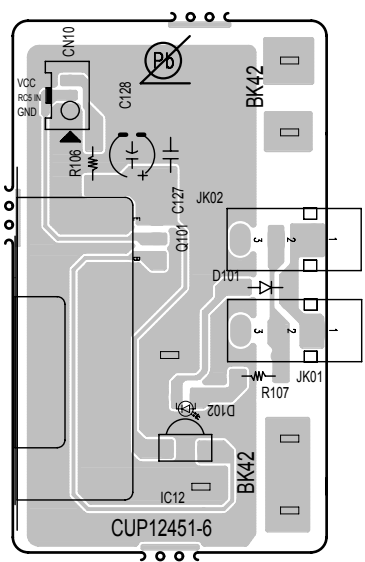

**REMOTE CONTROL
(FOIL SIDE)**

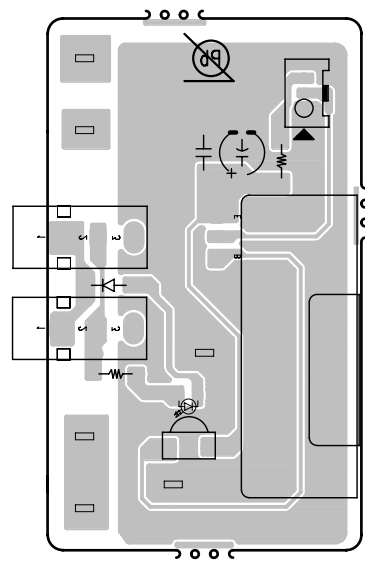

**POWER SW
(COMPONENT SIDE)**

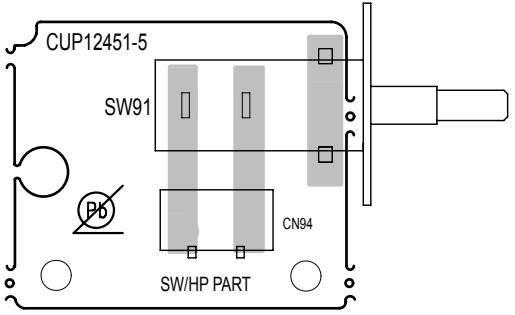

**POWER SW
(FOIL SIDE)**

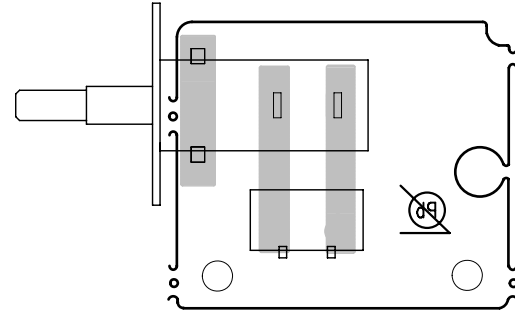

**VOLUME
(COMPONENT SIDE)**

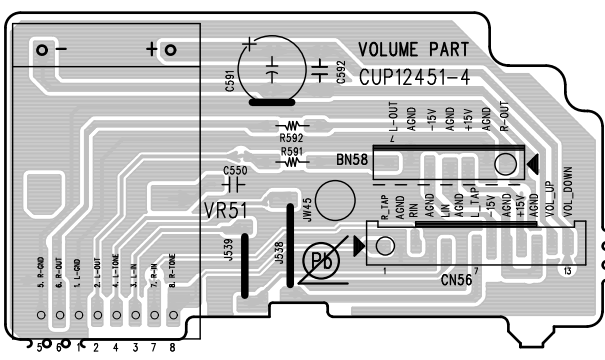

**VOLUME
(FOIL SIDE)**

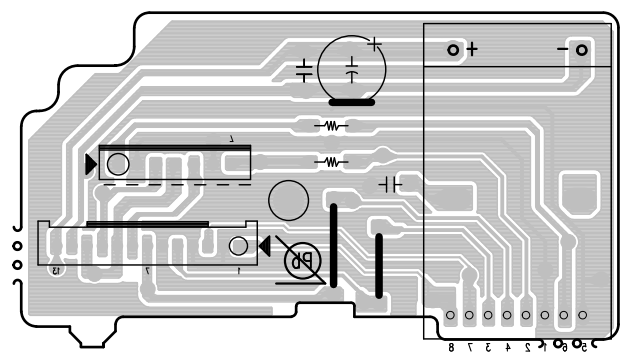

**FUNCTION
(COMPONENT SIDE)**

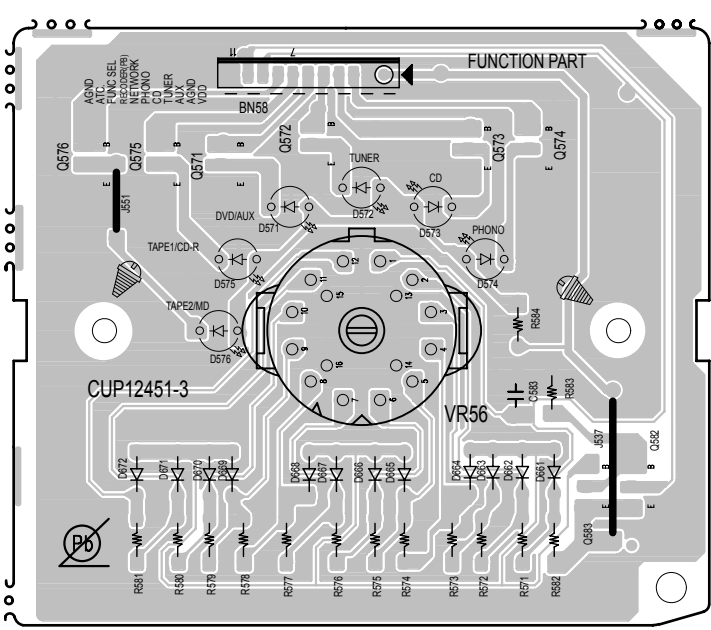

**FUNCTION
(FOIL SIDE)**

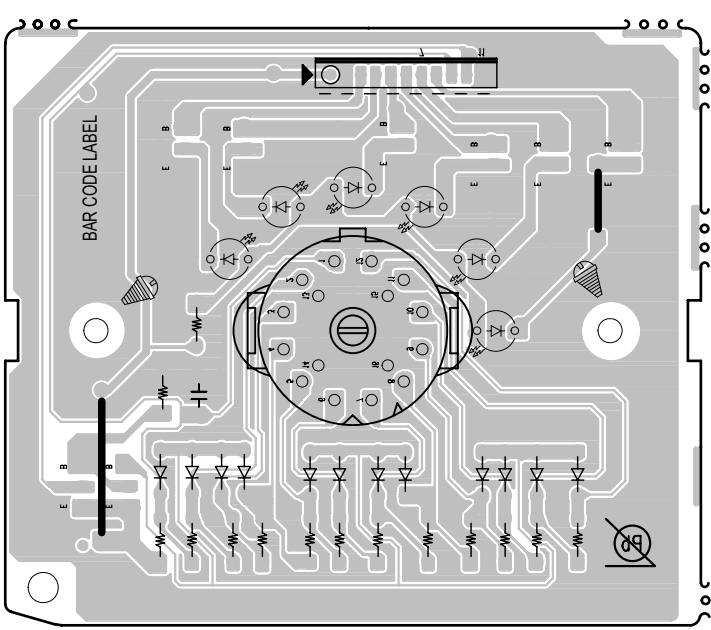

鉛フリー半田
半田付けには、鉛フリー半田 (Sn-Ag-Cu) を使用してください。

Lead-free Solder
When soldering, use the Lead-free Solder (Sn-Ag-Cu).

FRONT SCHEMATIC DIAGRAM

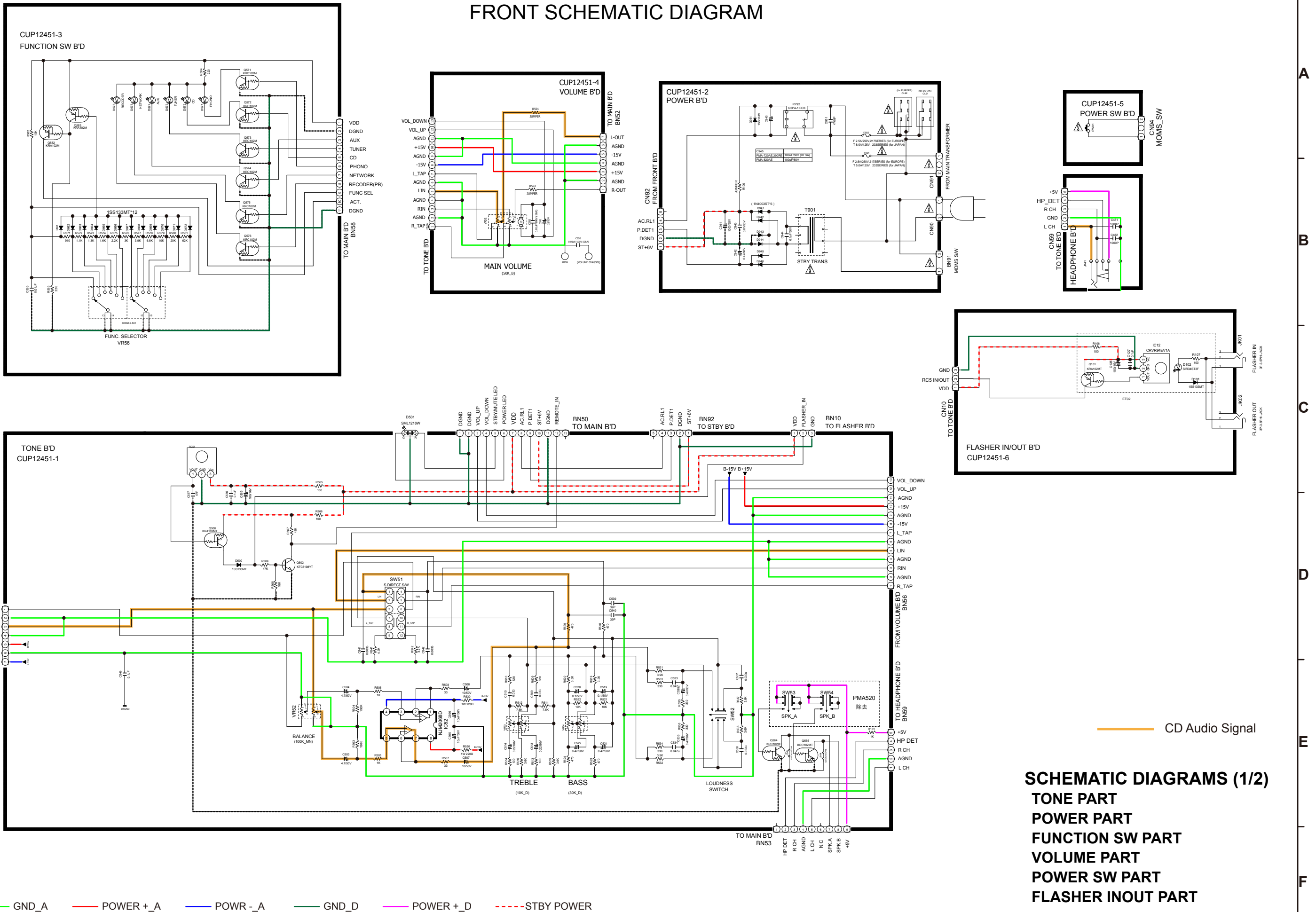

SCHEMATIC DIAGRAMS (1/2)
 TONE PART
 POWER PART
 FUNCTION SW PART
 VOLUME PART
 POWER SW PART
 FLASHER INOUT PART

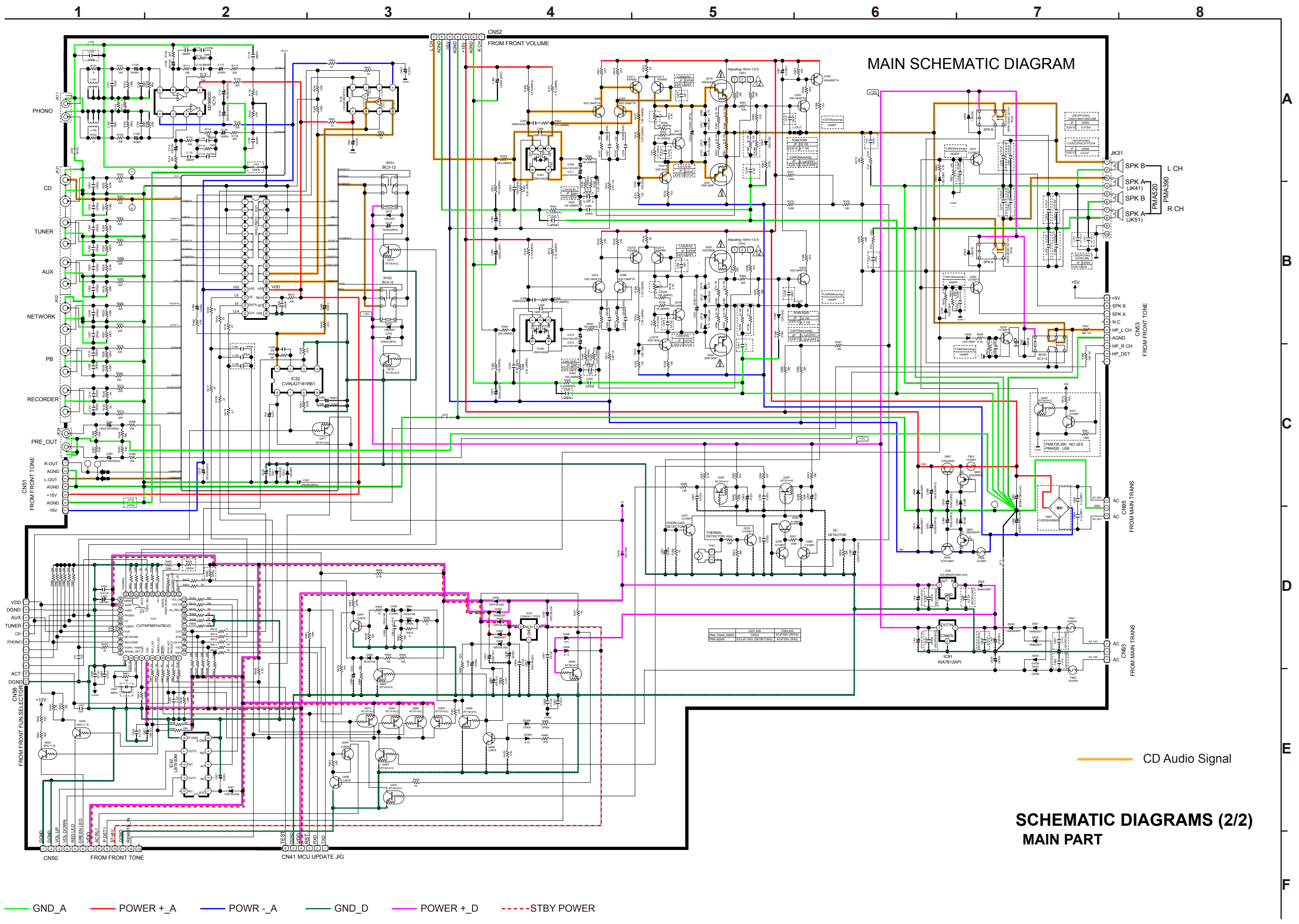

MAIN SCHEMATIC DIAGRAM

SCHEMATIC DIAGRAMS (2/2)
MAIN PART

- GND_A
- POWER +_A
- POWR -_A
- GND_D
- POWER +_D
- STBY POWER

— CD Audio Signal

EXPLODED VIEW (PMA-720AE)

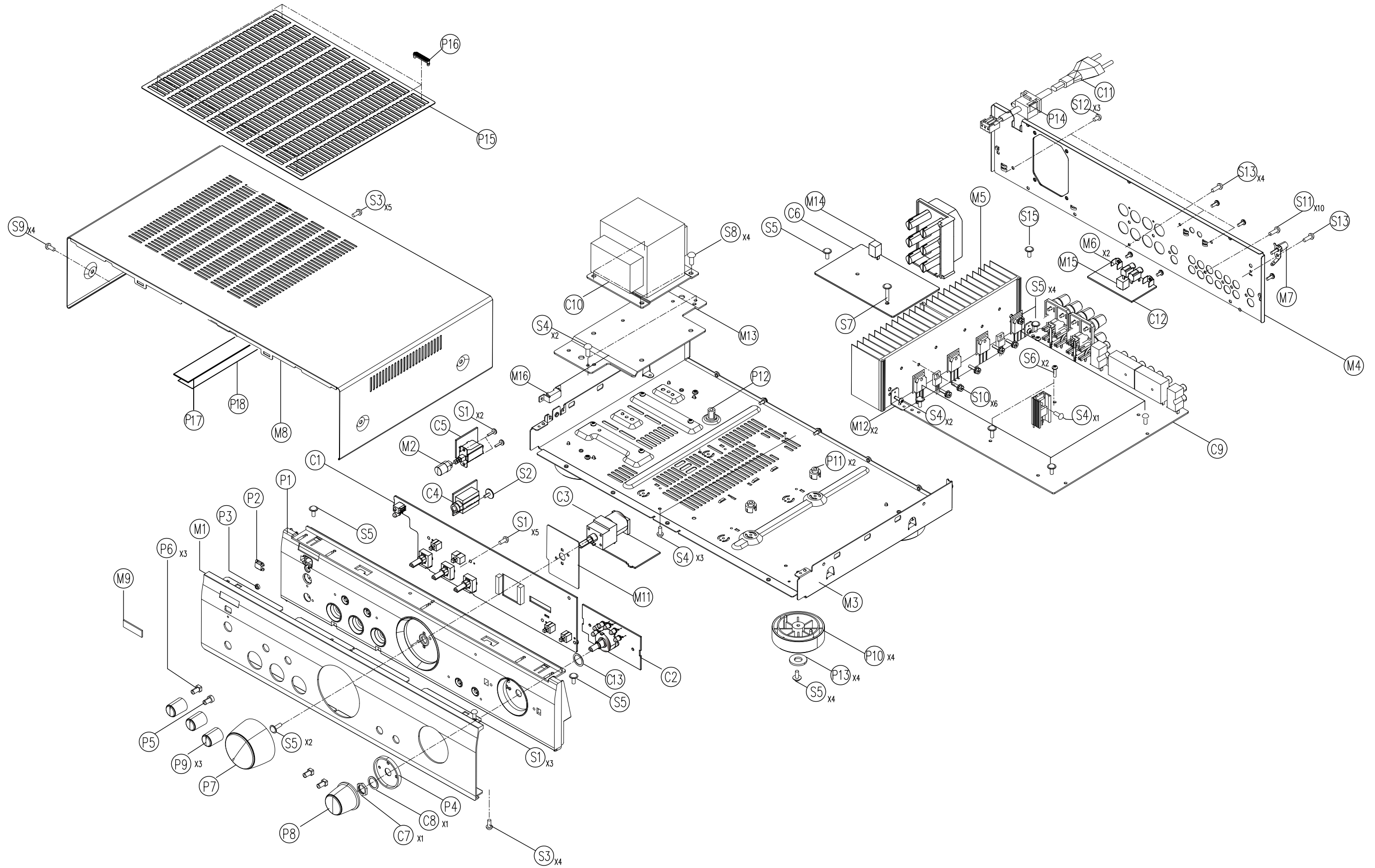

WARNING:
Parts marked with this symbol  have critical characteristics.
Use ONLY replacement parts recommended by the manufacturer.

PARTS LIST OF EXPLODED VIEW (PMA-720AE)

*Parts indicated by "nsp" on this table cannot be supplied.

*P.W.B. ASS'Y indicated by "nsp" on this table cannot be supplied. When repairing the P.W.B. ASS'Y, check the board parts list and order replacement parts.

*Parts indicated by the "★" mark are not illustrated in the exploded view.

*The parts listed below are only for maintenance. Therefore they might differ from the parts used in the unit in appearances or dimensions.

Note: The symbols in the column "Remarks" indicate the following destinations.

E2 : Europe model E1C : China model
BK : Black model SP : Premium Silver model

Ref. No.	Part No.	Part Name	Remarks	Q'ty	New
C1A	nsp	FRONT PCB ASSY		COP12451Z_A	1 *
C1	-	FRONT PCB		-	
C2	-	FUNCTION PCB		-	
C3	-	VOLUME PCB		-	
C4	-	POWER SW PCB		-	
C5	-	HEADPHONE PCB		-	
C6	-	POWER PCB		-	
C12	-	REMOTE CONTROL PCB		-	
C9	nsp	MAIN PCB ASSY		COP12450Z	1 *
C7	nsp	NUT(M9)		-	1
C8	nsp	WASHER		-	1
△ C10	943101101770D	POWER TRANSFORMER	E2	CLT5R044ZE	1 *
△ C10	943101101780D	POWER TRANSFORMER	E1C	CLT5R044ZH	1 *
△ C11	00D9430180407	CORD , POWER(EUR)	E2	CJA2B043ZA	1
△ C11	90M-YC000790R	AC CORD	E1C	CJA2N047ZA	1
C13	nsp	WASHER		CMC1A443	1
M1	943402102400D	FRONT PANEL_720BK	BK	CKM1A247ZC45	1 *
M1	943402102390D	FRONT PANEL_720SP	SP	CKM1A247YC62	1 *
M2	00D9430179502	POWER KNOB	BK	CGK1A124ZA	1
M2	00D9430179609	POWER KNOB	SP	CGK1A124YA	1
M3	nsp	CHASSIS,BOTTOM		CUA6A269	1
M4	nsp	PANEL , REAR_720E2	E2	CKF6A317Z	1
M4	nsp	REAR PANEL	E1C	CKF8A317Z(E1C)	1
M5	nsp	HEATSINK , MAIN		CMY1A329	1
M6	nsp	BRACKET , PCB		CMD1A569	1
M7	nsp	TERMINAL , GROUND		CMA1A006	1
M8	943403100640D	CABINET , TOP	BK	CKC1A176K117	1 *
M8	943403100650D	CABINET , TOP	SP	CKC1A176D11	1 *
M9	42141002300AD	BADGE , DENON	BK	-	1 *
M9	42141002301AD	BADGE , DENON	SP	-	1 *
M11	nsp	PLATE , SHIELD		CMC2A307	1
M12	nsp	BRACKET , PCB		CMD1A417	2
M13	nsp	BRACKET , TRANS		CMD1A808	1 *
M14	nsp	BRACKET , PCB(A)		CMD1A188	1
M15	nsp	SHIELD , CASE FLASHER		CMC1A441	1 *
P1	943443100580D	INNER PANEL_720BK	BK	CGW1A523B28	1 *
P1	943443100590D	INNER PANEL_720SP	SP	CGW1A523G45	1 *
P2	00D9430190206	WINDOW , REMOCON	BK	CGU1A396A8	1
P2	00D9430190109	WINDOW , REMOCON	SP	CGU1A396	1
P3	00D9430189903	LENS		CGL1A254	1

Ref. No.	Part No.	Part Name	Remarks	Q'ty	New
P4	943423004870D	FUNCTION LENS	BK	CGL1A255Z	1
P4	00D9430190002	FUNCTION LENS	SP	CGL1A255Y	1
P5	00D9430187109	KNOB , DIRECT	BK	CBC1A154B28	1
P5	00D9430187206	KNOB , DIRECT	SP	CBC1A154RGG45	1
P6	00D9430201505	KNOB , PUSH	BK	CBC2A155B28	3
P6	943412100910D	KNOB , PUSH	SP	CBC2A155RGG45	3 *
P7	943412100800D	KNOB , VOLUME	BK	CBN1A266	1 *
P7	943412100810D	KNOB , VOLUME	SP	CBN1A266MBC73	1 *
P8	943412100820D	KNOB , INPUT	BK	CBN1A267	1 *
P8	943412100830D	KNOB , INPUT	SP	CBN1A267MBC73	1 *
P9	943412100840D	KNOB , ROTARY	BK	CBN1A268	3 *
P9	943412100850D	KNOB , ROTARY	SP	CBN1A268MBC73	3 *
P10	nsp	FOOT		CKL1A093	4
P11	nsp	HOLDER , PCB		CHE170	2
P12	nsp	HOLDER , PCB		CHE2A030	1
P13	nsp	CUSHION , FOOT		CHG2A289	4
P14	nsp	BUSHING , AC CORD		CHR1A028	1
P15	nsp	SHEET , TOP		CGX1A382	1
P16	nsp	STOPPER , SHEET		CMH1A263	4
P17	nsp	BUTYL TAPE(25X170X2.0)		CMX1A191	
P18	nsp	NTOFLON TAPE(25X170X0.08)		CHS1A158	
★ 1	943649006160D	PIN , SHORT (PHONO)		CJT1A100	2
★ 2	nsp	TAPE , HEMELON		CHS1A032	8
★ 3	nsp	LOCKER		CRE1A037	8
★ 4	nsp	CLAMPER , WIRE		CHE36-3	2
★ 5	nsp	RUBBER CUSHION		CHG1A543	1
★ 6	nsp	CLAMPER		CHR301	8
★ 7	nsp	INSULATOR		CMX1A188	1
★ 8	nsp	TUBE , UL		C4B120122	
★ 9	nsp	LABEL , POP		CQB1A1114Y	1 *
★ 10	nsp	LABEL , HOT		CQB1A906Z	1 *
★ 11	nsp	CLAMPER , ARM		CHE154	
SCREWS					
S1	nsp	SCREW		CTB3+8JFN	10
S2	nsp	SCREW		CTWS3+10GR	1
S3	nsp	SCREW	SP	CTBD3+8JFN	9
S3	nsp	SCREW	BK	CTBD3+8JFZR	9
S4	nsp	SCREW		CTB3+8JR	8
S5	nsp	SCREW		CTW3+8JR	13
S6	nsp	SCREW		CTW3+12JR	2
S7	nsp	SCREW		CTW3+18JR	1
S8	nsp	SCREW		CHDR1A023R	4
S9	nsp	SCREW	SP	CTWD4+6FFN	4
S9	nsp	SCREW	BK	CTWD4+6FFZR	4
S10	nsp	SCREW		CHD1A012R	6
S11	nsp	SCREW		CTBD3+10GFZR	10
S12	nsp	SCREW		CTB3+6FFZR	3
S13	nsp	SCREW		CTBD3+8JFZR	5

PACKING VIEW (PMA-720AE)

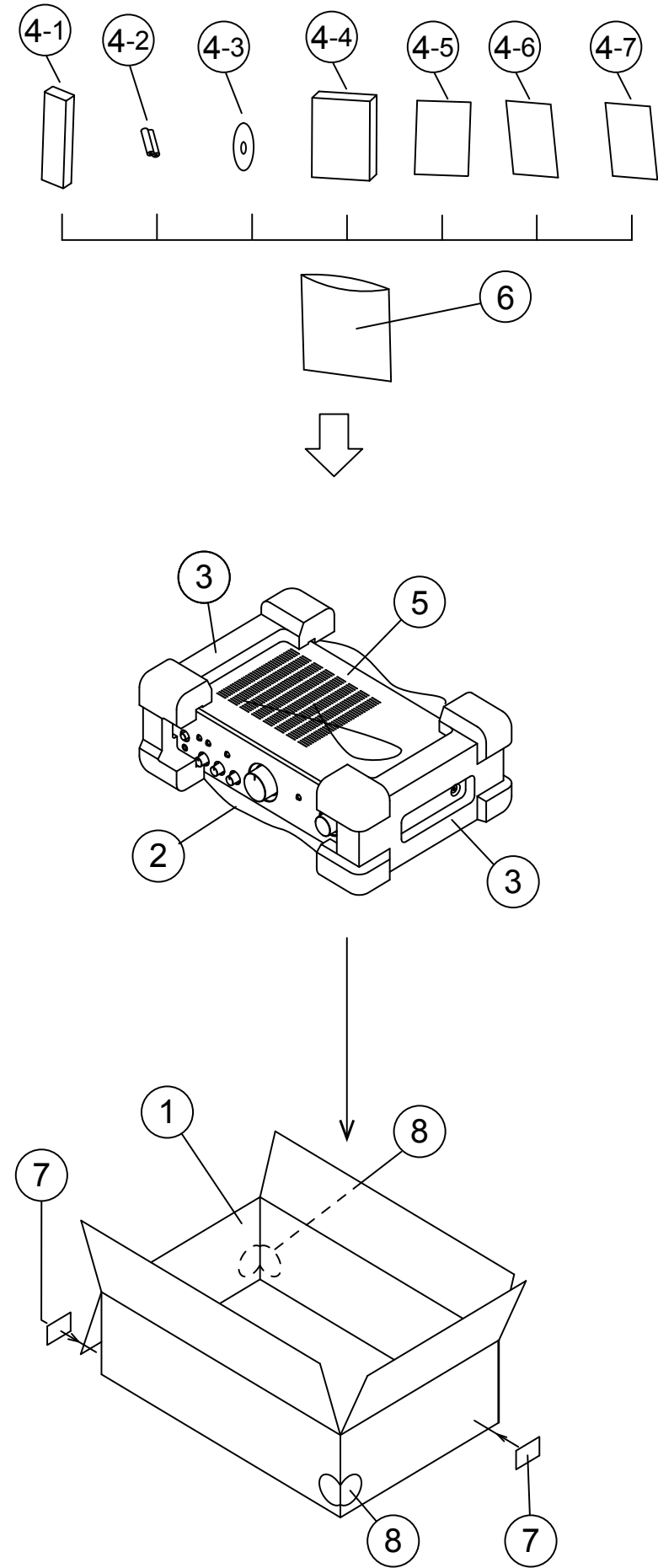

PARTS LIST OF PACKING & ACCESSORIES (PMA-720AE)

*Parts indicated by "nsp" on this table cannot be supplied.

*Parts indicated by the "★" mark are not illustrated in the exploded view.

*The parts listed below are only for maintenance. Therefore they might differ from the parts used in the unit in appearances or dimensions.

Note: The symbols in the column "Remarks" indicate the following destinations.
 E2 : Europe model
 BK : Black model
 E1C : China model
 SP : Premium Silver model

Ref. No.	Part No.	Part Name	Remarks		Q'ty	New	
1	943531102590D	OUT CARTON BOX	made in China	CPG2A818L	1	*	⚠️
1	943531104830D	OUT CARTON BOX	made in Vietnam	VPG2A818L	1	*	⚠️
2	nsp	BAG , POLY		CPB1A013Y	1		
3	943533101210D	PAD , SNOW		CPS3A747	2		
4	-	INSTRUCTIONMANUAL ASS'Y		-	1		
4-1	943307101180D	REMOCON TRANSMITTER ASS'Y (RC-1173)		CARTDCD720A1	1	*	
4-2	nsp	BATTERY , AAA 2PCS IN PACK		CABR03PPB	2		
4-3	35251013500AD	CD ROM MANUAL ASS'Y (PMA-720/520AE E2)	E2	CFT1A070ZA	1	*	
4-4	54111087900AD	GETTING STARTED _IM (E2)	E2	CQX1A1687Z	1	*	
4-4	54111086500AD	INST.MANUAL (PMA-720AE E1C)	E1C	CQX1A1691Z	1	*	
4-5	nsp	LIST , S.S		CQE1A226P	1		
6	nsp	BAG , POLY		CPB1061W	1		
7	nsp	CONTROL, LABEL		CQB1A993Z	1		
8	nsp	LABEL , COLOR LABEL(WHITE)	SP	CQB1A676	1		

EXPLODED VIEW (PMA-520AE)

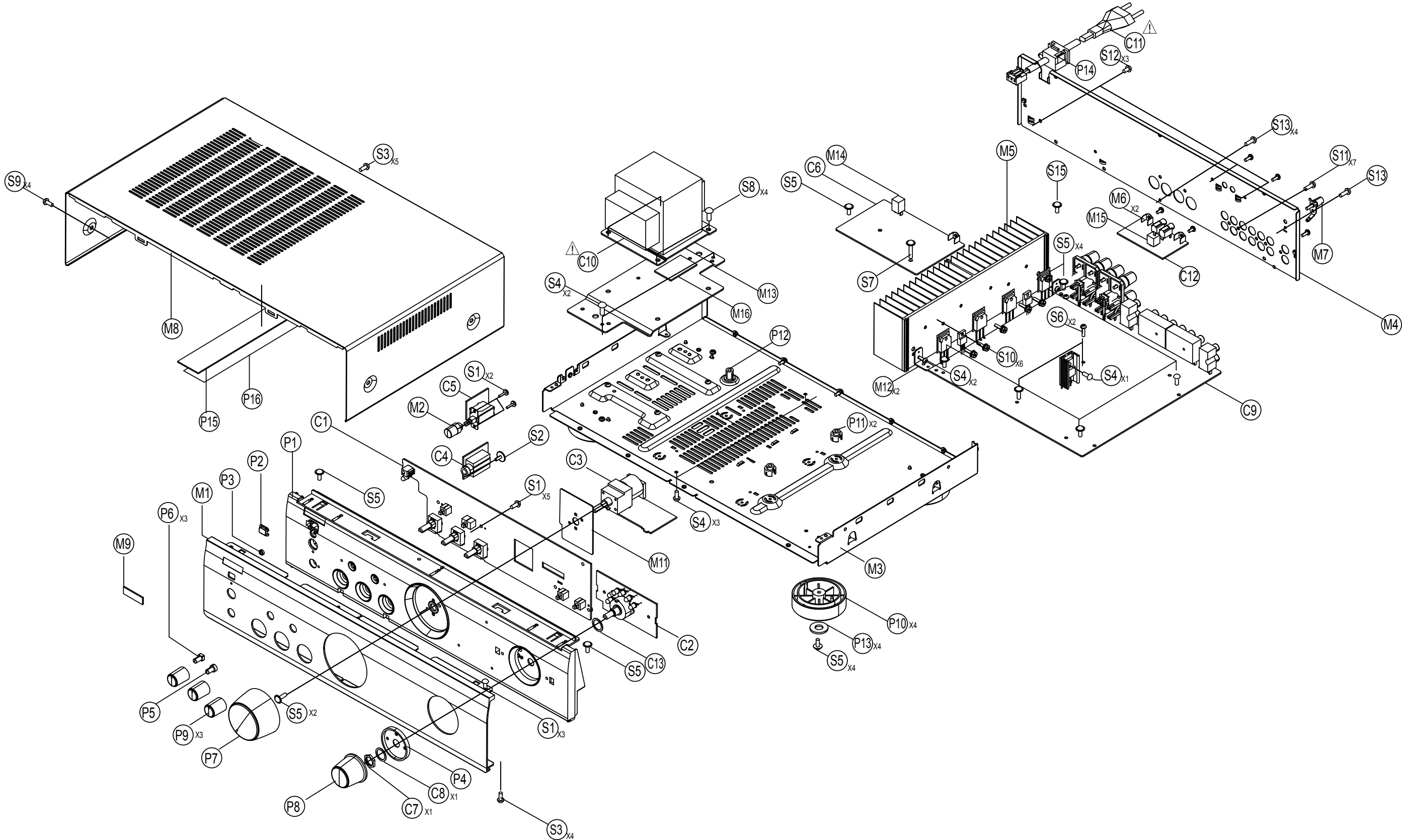

WARNING:
 Parts marked with this symbol  have critical characteristics.
 Use ONLY replacement parts recommended by the manufacturer.

PARTS LIST OF EXPLODED VIEW (PMA-520AE)

*Parts indicated by "nsp" on this table cannot be supplied.

*P.W.B. ASS'Y indicated by "nsp" on this table cannot be supplied. When repairing the P.W.B. ASS'Y, check the board parts list and order replacement parts.

*Parts indicated by the "★" mark are not illustrated in the exploded view.

*The parts listed below are only for maintenance. Therefore they might differ from the parts used in the unit in appearances or dimensions.

Note: The symbols in the column "Remarks" indicate the following destinations.

E2 : Europe model

E1C : China model

BK : Black model

SP : Premium Silver model

Ref. No.	Part No.	Part Name	Remarks	Q'ty	New
C1A	nsp	FRONT PCB ASSY		COP12451Z	1 *
C1	-	FRONT PCB		-	
C2	-	FUNCTION PCB		-	
C3	-	VOLUME PCB		-	
C4	-	POWER SW PCB		-	
C5	-	HEADPHONE PCB		-	
C6	-	POWER PCB		-	
C12	-	REMOTE CONTROL PCB		-	
C9	nsp	MAIN PCB ASSY		COP12450Z	1 *
C7	nsp	NUT(M9)		-	1
C8	nsp	WASHER		-	1
△ C10	943101101750D	TRANS , POWER(EI74 X 62)	E2	CLT5R045ZE	1 *
△ C10	943101101760D	TRANS , POWER(EI74 X 62)	E1C	CLT5R045ZH	1 *
△ C11	00D9430180407	CORD , POWER(EUR)	E2	CJA2B043ZA	1
△ C11	90M-YC000790R	CORD , POWER(EUR)	E1C	CJA2N047ZA	1
C13	nsp	WASHER		CMC1A443	1
M1	943402102290D	FRONT PANEL_520BK	BK	CKM2A247ZC45	1 *
M1	943402102300D	FRONT PANEL_520SP	SP	CKM2A247YC62	1 *
M2	00D9430179502	KNOB , POWER	BK	CGK1A124ZA	1
M2	00D9430179609	KNOB , POWER	SP	CGK1A124YA	1
M3	nsp	CHASSIS,BOTTOM		CUA6A269	1 *
M4	nsp	PANEL , REAR_520E2	E2	CKF9A317Z	1 *
M4	nsp	PANEL , REAR_520E1C	E1C	CKF8A317Z	1 *
M5	nsp	HEAT SINK		CMY2A329	1
M6	nsp	BRACKET , PCB		CMD1A569	2
M7	nsp	TERMINAL , GROUND		CMA1A006	1
M8	943403100640D	CABINET , TOP	BK	CKC1A176K117	1 *
M8	943403100650D	CABINET , TOP	SP	CKC1A176D11	1 *
M9	42141002300AD	BADGE , DENON	BK	-	1 *
M9	42141002301AD	BADGE , DENON	SP	-	1 *
M11	nsp	PLATE , SHIELD		CMC2A307	1 *
M12	nsp	BRACKET , PCB		CMD1A417	2
M13	nsp	BRACKET , TRANS		CMD1A808	1 *
M14	nsp	BRACKET , PCB(A)		CMD1A188	1
M15	nsp	SHIELD , CASE FLASHER		CMC1A441	1 *
M16	nsp	RUBBER CUSHION		CHG1A543	1 *
P1	943443100540D	INNER PANEL_520BK	BK	CGW2A523B28	1 *
P1	943443100550D	INNER PANEL_520BK	SP	CGW2A523G45	1 *
P2	00D9430190206	WINDOW , REMOCON	BK	CGU1A396A8	1
P2	00D9430190109	WINDOW , REMOCON	SP	CGU1A396	1
P3	00D9430189903	LENS		CGL1A254	1

Ref. No.	Part No.	Part Name	Remarks	Q'ty	New
P4	943423004870D	FUNCTION LENS	BK	CGL1A255Z	1
P4	00D9430190002	FUNCTION LENS	SP	CGL1A255Y	1
P5	00D9430187109	KNOB , DIRECT	BK	CBC1A154B28	1
P5	00D9430187206	KNOB , DIRECT	SP	CBC1A154RGG45	1
P6	00D9430201505	KNOB , PUSH	BK	CBC2A155B28	1
P6	943412100910D	KNOB , PUSH	SP	CBC2A155RGG45	1
P7	943412100800D	KNOB , VOLUME BK	BK	CBN1A266	1 *
P7	943412100810D	KNOB , VOLUME	SP	CBN1A266MBC73	1 *
P8	943412100820D	KNOB , INPUT BK	BK	CBN1A267	1 *
P8	943412100830D	KNOB , INPUT	SP	CBN1A267MBC73	1 *
P9	943412100840D	KNOB , ROTARY BK	BK	CBN1A268	1 *
P9	943412100850D	KNOB , ROTARY	SP	CBN1A268MBC73	1 *
P10	nsp	FOOT		CKL1A093	4
P11	nsp	HOLDER , PCB		CHE170	2
P12	nsp	HOLDER , PCB		CHE2A030	1
P13	nsp	CUSHION , FOOT		CHG2A289	4
P14	nsp	BUSHING , AC CORD		CHR1A028	1
P15	nsp	BUTYL TAPE(25X170X2.0)		CMX1A191	
P16	nsp	NTOFLON TAPE(25X170X0.08)		CHS1A158	
★ 1	943649006160D	PIN , SHORT (PHONO)		CJT1A100	2
★ 2	nsp	CLAMPER , WIRE		CHE36-3	2
★ 3	nsp	CLAMPER , ARM		CHE154	
★ 4	nsp	HEAT SINK , TR		CMY1A043	1
★ 5	nsp	TAPE , HEMELON		CHS1A032	8
★ 6	nsp	TAPE , NITOFLO(25X170X0.08)		CHS1A158	
★ 7	nsp	BUTYL TAPE(25X100X2.0)		CMX1A191	
★ 8	nsp	TUBE , UL		C4B120122	
★ 9	nsp	LOCKER		CRE1A037	4
★ 10	nsp	CLAMPER		CHR301	8
★ 11	nsp	INSULATOR		CMX1A188	1 *
★ 12	nsp	LABEL , POP		CQB1A1114Z	1 *
★ 13	nsp	LABEL , HOT		CQB1A906Z	1
SCREWS					
S1	nsp	SCREW		CTB3+8JFN	10
S2	nsp	SCREW		CTWS3+10GR	1
S3	nsp	SCREW		CTBD3+8JFZR	9
S4	nsp	SCREW		CTB3+8JR	2
S4	nsp	SCREW		CTB3+8JR	1
S4	nsp	SCREW		CTB3+8JR	1
S4	nsp	SCREW		CTB3+8JR	5
S5	nsp	SCREW		CTW3+8JR	2
S5	nsp	SCREW		CTW3+8JR	2
S5	nsp	SCREW		CTW3+8JR	8
S6	nsp	SCREW		CTW3+12JR	2
S7	nsp	SCREW		CTW3+18JR	1
S8	nsp	SCREW , TRANS		CHDR1A023R	4
S9	nsp	SCREW		CTWD4+6FFZR	4
S10	nsp	SCREW , SPECIAL		CHD1A012R	6
S11	nsp	SCREW		CTBD3+10GFZR	9
S12	nsp	SCREW		CTB3+6FFZR	3
S13	nsp	SCREW		CTBD3+8JFZR	5

PACKING VIEW (PMA-520AE)

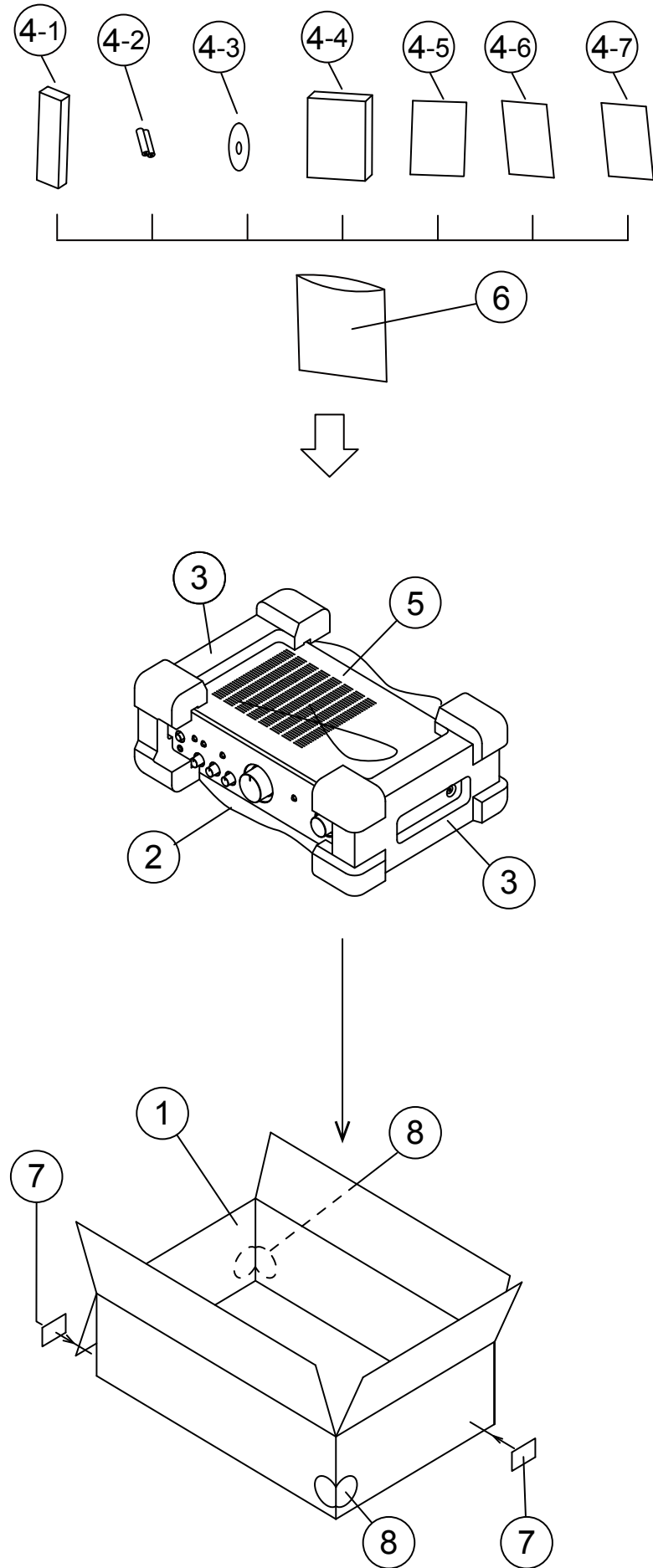

PARTS LIST OF PACKING & ACCESSORIES (PMA-520AE)

*Parts indicated by "nsp" on this table cannot be supplied.

*Parts indicated by the "★" mark are not illustrated in the exploded view.

*The parts listed below are only for maintenance. Therefore they might differ from the parts used in the unit in appearances or dimensions.

Note: The symbols in the column "Remarks" indicate the following destinations.

E2 : Europe model

E1C : China model

BK : Black model

SP : Premium Silver model

Ref. No.	Part No.	Part Name	Remarks		Q'ty	New
1	943531102450D	OUT CARTON BOX	made in China	CPG2A818K	1	*
1	943531104820D	OUT CARTON BOX	made in Vietnam	VPG2A818I	1	*
2	nsp	BAG , POLY		CPB1A013Y	1	
3	943533101210D	PAD , SNOW		CPS3A747	2	
4	-	INSTRUCTIONMANUAL ASS'Y		-	1	
4-1	943307101180D	REMOCON TRANSMITTER ASS'Y (RC-1173)		CARTDCD720A1	1	*
4-2	nsp	BATTERY , AAA 2PCS IN PACK		CABR03PPB	2	
4-3	35251013500AD	CD ROM MANUAL ASS'Y (PMA-720/520AE E2)	E2	CFT1A070ZA	1	*
4-4	54111087900AD	GETTING STARTED _IM (E2)	E2	CQX1A1687Z	1	*
4-4	54111086500AD	INST.MANUAL (PMA-720AE E1C)	E1C	CQX1A1691Z	1	*
4-5	nsp	LIST , S.S		CQE1A226P	1	
4-6	nsp	WARRANTY CARD, CHINA	E1C	CQE1A473Y	1	
4-7	nsp	CARD FOR CHINA IDENTIFICAT	E1C	CQE1A450Z	1	
6	nsp	BAG , POLY		CPB1061W	1	
7	nsp	CONTROL, LABEL		CQB1A993Z	1	
8	nsp	LABEL , COLOR LABEL(WHITE)	SP	CQB1A676	1	



SEMICONDUCTORS

Only major semiconductors are shown. General semiconductors etc. are omitted from list.
The semiconductors which have a detailed drawing in a schematic diagram are omitted from list.

1. IC's

TMP86FH47BUG (MAIN :IC41)

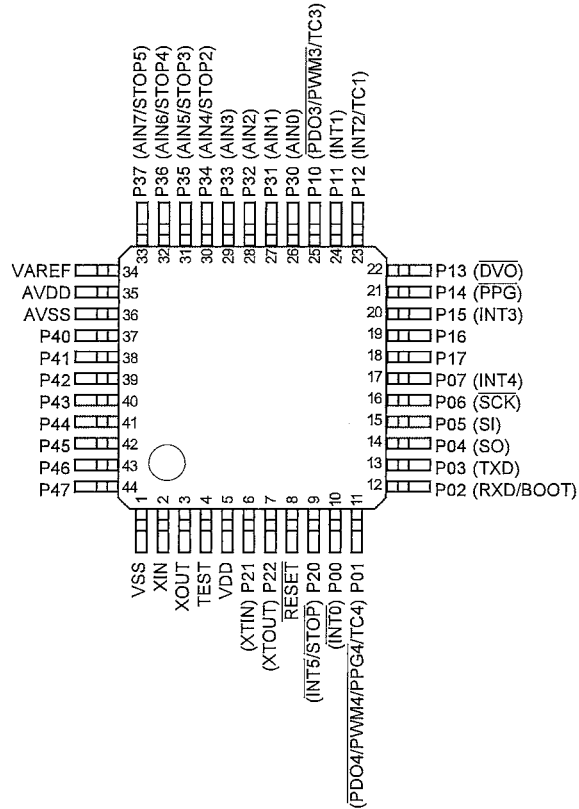

TMP86FH47BUG Terminal Functions

pin	port	I/O	function	active	normal
1	VSS		to GND		
2	XIN	I	x'tal		
3	XOUT	O	x'tal		
4	TEST		to VSS/VDD		
5	VDD		to 3.3v		
6	P21(XTIN)	O	LED RED	H	L
7	P22(XTOUT)	O	LED GREEN	H	L
8	REST	I	reset		
9	P20(STOP/INT5)	I	Stop mode cancellation	HIGH edge	L
10	P00(INT0)	I	ASO/DC protector	LOW edge	H
11	P01(TC4)	O	NC	-	Fixed L
12	P02(RXD)	I	RXD(prom)	L	H
13	P03(TXD)	O	TXD(prom)	L	H
14	P04(SO)	O	analog sw data	H	L
15	P05(SI)	O	analog sw strobe	H	L
16	P06(SCK)	O	analog sw clock	H	L
17	P07(INT4)	O	NC	-	Fixed L
18	P17	I	NC	-	Fixed L
19	P16	I	NC	-	Fixed L
20	P15(INT3)	O	ac power relay	H	L

21	P14(PPG)	O	volume up	H	L
22	P13(DVO)	O	volume down	H	L
23	P12(INT2)	I	remocon input	L	H
24	P11(INT1)	I	Power off (power failure)	H	L
25	P10(TC3)	O	timer reset	L	H
26	P30(AIN0)	I	Model switch	AD	AD
27	P31(AIN1)	I	NC	-	Fixed L
28	P32(AIN2)	I	NC	-	Fixed L
29	P33(AIN3)	I	function selector	eddge/AD	
30	P34(AIN4/STOP2)	O	head phone/muting	H	L
31	P35(AIN5/STOP3)	O	NC	-	Fixed L
32	P36(AIN6/STOP4)	O	NC	-	Fixed L
33	P37(AIN7/STOP5)	I	THERMAL protector	LOW eddge	H
34	VAREF		to VDD		
35	AVDD		to VDD		
36	AVSS		to VSS		
37	P40	O	PHONO LED/relay drive	H	L
38	P41	O	CD LED/relay drive	H	L
39	P42	O	TUNER LED	H	L
40	P43	O	AUX LED	H	L
41	P44	O	NETWORK LED	H	L
42	P45	O	RECORDER LED	H	L
43	P46	I	SIG. Timer	L	H
44	P47	I	NC	-	Fixed H

LC78212 (MAIN : IC21)

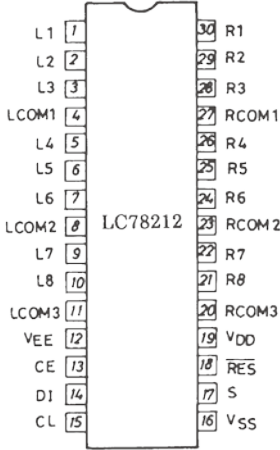

Top View

LC78212 Block diagram

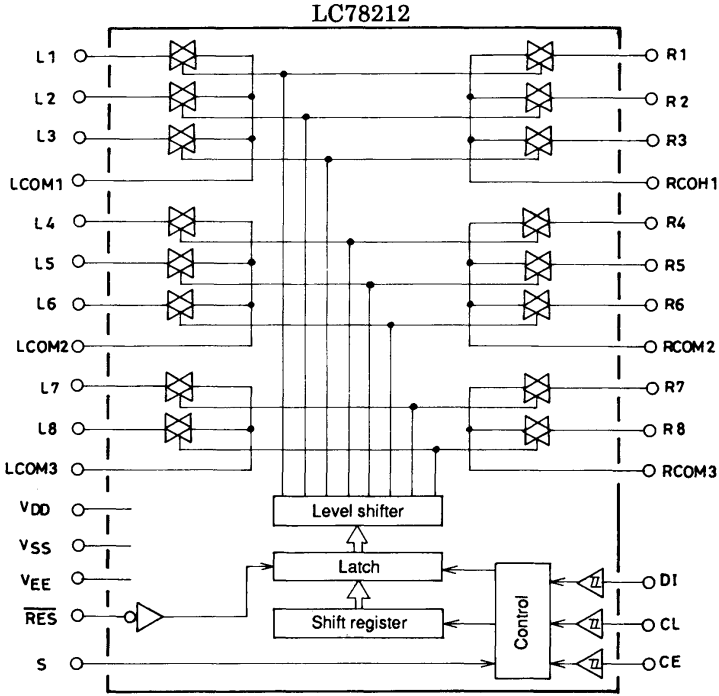

ILC7812 Terminal Functions

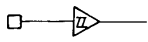
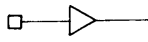
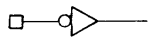
Pin	I/O	Internal equivalent circuit	Pin function																																											
V _{DD} , V _{SS} , V _{EE}			Power supply																																											
L1 to L8, R1 to R8, LCOM1 to LCOM4, RCOM1 to RCOM4		See the block diagram.	Analog switch input and output																																											
CL, DI, CE	I		Serial data input (Schmitt buffer) CL.....Clock input DI.....Data input CEChip enable																																											
S	I		Selection of one of two chips The address is set to the values shown in the table below according to the level input to the S pin. <table border="1" data-bbox="735 600 1278 831"> <thead> <tr> <th rowspan="2">Product</th> <th rowspan="2">S pin level</th> <th colspan="4">Address</th> </tr> <tr> <th>A₀</th> <th>A₁</th> <th>A₂</th> <th>A₃</th> </tr> </thead> <tbody> <tr> <td rowspan="2">LC78211</td> <td>L</td> <td>0</td> <td>1</td> <td>0</td> <td>1</td> </tr> <tr> <td>H</td> <td>1</td> <td>1</td> <td>0</td> <td>1</td> </tr> <tr> <td rowspan="2">LC78212</td> <td>L</td> <td>0</td> <td>0</td> <td>1</td> <td>1</td> </tr> <tr> <td>H</td> <td>1</td> <td>0</td> <td>1</td> <td>1</td> </tr> <tr> <td rowspan="2">LC78213</td> <td>L</td> <td>0</td> <td>1</td> <td>1</td> <td>1</td> </tr> <tr> <td>H</td> <td>1</td> <td>1</td> <td>1</td> <td>1</td> </tr> </tbody> </table>	Product	S pin level	Address				A ₀	A ₁	A ₂	A ₃	LC78211	L	0	1	0	1	H	1	1	0	1	LC78212	L	0	0	1	1	H	1	0	1	1	LC78213	L	0	1	1	1	H	1	1	1	1
Product	S pin level	Address																																												
		A ₀	A ₁	A ₂	A ₃																																									
LC78211	L	0	1	0	1																																									
	H	1	1	0	1																																									
LC78212	L	0	0	1	1																																									
	H	1	0	1	1																																									
LC78213	L	0	1	1	1																																									
	H	1	1	1	1																																									
$\overline{\text{RES}}$	I		Reset input The states of the analog switches are undefined when power is first applied. Setting this pin low will force all switches the off state.																																											

PARTS LIST OF P.C.B. UNIT

*Parts indicated by "nsp" on this table cannot be supplied.

*The parts listed below are only for maintenance. Therefore they might differ from the parts used in the unit in appearances or dimensions.

Note: The symbols in the column "Remarks" indicate the following destinations.

E2 : Europe model

E1C : China model

FRONT PCB ASSY (PMA-720AE)

Ref. No.	Part No.	Part Name	Remarks	Q'ty	New
SEMICONDUCTORS GROUP					
IC12	262010007707S	REMOTE SENSOR , R94EV1A		CRVR94EV1A	
IC52	00D2630609002	I.C , OP AMP NJM2068DD		HVINJM2068DD	
Q101	00D9430154200	TR KRA102M		HVTKRA102MT	
Q500	00D9430154200	TR KRA102M		HVTKRA102MT	
Q502	00D9430154404	TR KTC3198Y		HVTKTC3198YT	
Q564,565	00D9430107804	TR KRC102M		HVTKRC102MT	
Q571-576	00D9430107804	TR KRC102M		HVTKRC102MT	
Q582,583	00D9430154200	TR KRA102M		HVTKRA102MT	
D101	00D9430182609	DIODE , SWITCHING, 1SS133		CVD1SS133MT	
D102	963262010460S	L.E.D (Infrared light emitting SIR-341ST3F		CVDSIR341ST3FT0	
D500	00D9430182609	L.E.D, SIR-341ST3F		CVD1SS133MT	
D501	943263100630D	5mm 2 COLOR Red Green LED		CVDGY5Y5U03Y2WGAAHB	*
D571-576	943263100640D	3mm Yellow LED		CVDGY34MR02Y415AJTHA	*
D661-672	00D9430182609	DIODE , SWITCHING, 1SS133		CVD1SS133MT	
D941-946	00D9430182502	DIODE , RECT 1N4003		CVD1N4003ST	
D951	00D9430182609	DIODE , SWITCHING, 1SS133		CVD1SS133MT	
RESISTORS GROUP					
R101	nsp	RES, CARBON(1/5W,1Kohm,J)		CRD20TJ102T	
R106,107	nsp	RES, CARBON(1/5W,100ohm,J)		CRD20TJ101T	
R503,504	nsp	RES, CARBON(1/5W,150Kohm,J)		CRD20TJ154T	
R505,506	nsp	RES, CARBON(1/5W,1Kohm,J)		CRD20TJ102T	
R507,508	nsp	RES, CARBON(1/5W,33ohm,J)		CRD20TJ330T	
R509,510	nsp	RES, CARBON(1/5W,820ohm,J)		CRD20TJ821T	
R511,512	nsp	RES, CARBON(1/5W,7.5Kohm,J)		CRD20TJ752T	
R513,514	nsp	RES, CARBON(1/5W,100ohm,J)		CRD20TJ101T	
R515,516	nsp	RES, CARBON(1/5W,3.6Kohm,J)		CRD20TJ362T	
R519,520	nsp	RES, CARBON(1/5W,3.3Kohm,J)		CRD20TJ332T	
R521,522	nsp	RES, CARBON(1/5W,10Kohm,J)		CRD20TJ103T	
R523,524	nsp	RES, CARBON(1/5W,470ohm,J)		CRD20TJ471T	
R530	nsp	RES, M-OXIDE FILM(1W/220ohm)		CRG1SANJ221RT	
R531,532	nsp	RES, CARBON(1/5W,3.9Kohm,J)		CRD20TJ392T	
R533-536	nsp	RES, CARBON(1/5W,330ohm,J)		CRD20TJ331T	
R537,538	nsp	RES, CARBON(1/5W,3.6Kohm,J)		CRD20TJ362T	
R539,540	nsp	RES, CARBON(1/5W,470ohm,J)		CRD20TJ471T	
R541,542	nsp	RES, CARBON(1/5W,4.7Kohm,J)		CRD20TJ472T	
R550	nsp	RES, M-OXIDE FILM(1W/220ohm)		CRG1SANJ221RT	
R565,566	nsp	RES, CARBON(1/5W,100ohm,J)		CRD20TJ101T	
R567	nsp	RES, CARBON(1/5W,47Kohm,J)		CRD20TJ473T	
R568	nsp	RES, CARBON(1/5W,18Kohm,J)		CRD20TJ183T	
R569	nsp	RES, CARBON(1/5W,47Kohm,J)		CRD20TJ473T	
R571	nsp	RES, CARBON(1/5W,910ohm,J)		CRD20TJ911T	
R572	nsp	RES, CARBON(1/5W,1.1Kohm,J)		CRD20TJ112T	
R573	nsp	RES, CARBON(1/5W,1.3Kohm,J)		CRD20TJ132T	
R574	nsp	RES, CARBON(1/5W,1.6Kohm,J)		CRD20TJ162T	
R575	nsp	RES, CARBON(1/5W,2.2Kohm,J)		CRD20TJ222T	
R576	nsp	RES, CARBON(1/5W,3Kohm,J)		CRD20TJ302T	
R577	nsp	RES, CARBON(1/5W,3.9Kohm,J)		CRD20TJ392T	
R578	nsp	RES, CARBON(1/5W,6.8Kohm,J)		CRD20TJ682T	
R579	nsp	RES, CARBON(1/5W,10Kohm,J)		CRD20TJ103T	
R580	nsp	RES, CARBON(1/5W,20Kohm,J)		CRD20TJ203T	
R581	nsp	RES, CARBON(1/5W,62Kohm,J)		CRD20TJ623T	
R582	nsp	RES, CARBON(1/5W,10Kohm,J)		CRD20TJ103T	
R583	nsp	RES, CARBON(1/5W,22Kohm,J)		CRD20TJ223T	

Ref. No.	Part No.	Part Name	Remarks	Q'ty	New
R584	nsp	RES, CARBON(1/5W,220ohm,J)		CRD20TJ221T	
R591,592	nsp	RES, CARBON(1/5W,1Kohm,J)		CRD20TJ102T	
VR51	00D9430197305	VOLUME , MOTOR		CVV9Y13B503Z	
VR52	00D9430197101	RES , VARIABLE BALANCE RA1450GOE0D-HA1		CVV2X13M104Z	
VR53	00D9430197208	TONE VR D103-Q1-FB200B1		CVV2X18D103Z	
VR54	00D9430215504	TONE VR D303-Q1-FB200B1		CVV2X19D303Z	
VR56	00D9430195200	SW , ROTARY		CSRCA001Z	
CAPACITORS GROUP					
C127	nsp	CAP , CERAMIC 0.1UF 50V		CCBS1H104ZFT	
C128	nsp	CAP, ELECT(10V/100uF)		CCEA1AH101T	
C481,482	nsp	CAP, CERAMIC(50V/1000pF/K)		CCKT1H102KB	
C503,504	nsp	CAP, ELECT(50V/4.7uF)		CCEA1HH4R7T	
C505-508	nsp	CAP, ELECT(50V/10uF)		CCEA1HH100T	
C509,510	nsp	CAP , MYLAR(50V/0.033uF/J)		CCQ1H333JZT	
C513,514	nsp	CAP, ELECT(50V/0.22uF)		CCEA1HHR22T	
C519,520	nsp	CAP, ELECT(50V/0.1uF)		CCEA1HH0R1T	
C521,522	nsp	CAP, ELECT(50V/0.47uF)		CCEA1HHR47T	
C533,534	nsp	CAP , MYLAR(50V/0.047uF/J)		CCQ1H473JZT	
C535,536	nsp	CAP, ELECT(50V/0.47uF)		CCEA1HHR47T	
C537,538	nsp	CAP , MYLAR(50V/0.033uF/J)		CCQ1H333JZT	
C539,540	nsp	CAP, CERAMIC(50V/39pF/J)		CCCT1H390JC	
C541,542	nsp	CAP, MYLAR(50V/3300pF/J)		HCQ1H332JZT	
C549	nsp	CAP , SEMICONDUCTOR 0.1uF 50V ZF		CCFT1H104ZF	
C565	nsp	CAP, ELECT(16V/100uF)		CCEA1CH101T	
C566	nsp	CAP , CEMICONDUCTOR 0.1uF 50VZF		CCFT1H104ZF	
C567	nsp	CAP, CERAMIC(50V/47pF/J)		CCCT1H470JC	
C583	nsp	CAP , CERAMIC CAP 0.01uF 50V Z		CCFT1H103ZF	
C591	nsp	CAP, ELECT(50V/22uF)		CCEA1HH220T	
C592	nsp	CAP , CERAMIC 0.01uF 50V Z		CCFT1H103ZF	
C941	943134501920D	CAP , ELECT(25V/1000uF)		CCEA1EH102EC	*
C942	00D9609010023	CAP, ELECT(50V/0.47uF)		CCEA1HHR47T	
C943	nsp	CAP , CERAMIC 0.01uF 50V Z		CCFT1H103ZF	
C944	nsp	CAP , SEMICONDUCTOR 0.1uF 50VZF		CCFT1H104ZF	
C945	943134502050D	E.CAP, 100UF/50V,ELNA RFSA(SILMIC II)		CCEA1HRFSA101E	*
C951	00D9430024408	CAP , CERAMIC(X1/Y2/SC) 0.0047uF 2.5KV		KCKDKS472ME	
OTHERS PARTS GROUP					
CN10	nsp	LOCKING TYPE, STRAIGHT WAFER 2MM		CJP03GI236ZW	
CN56	nsp	LOCK-WAFER/STRAIGHT/2mm		CJP13GI236ZW	
CN59	nsp	STRAIGHT WAFER 5PIN 2MM		CJP05GI236ZW	
CN90	nsp	WAFER, 2P, 3.96mm		CJP02KA060ZY	
CN91	nsp	WAFER, 2P, 7.92mm		CJP02GA89ZY	
CN92	nsp	LOCKING TYPE , STRAIGHT WAFER 5PIN 2MM		CJP05GI236ZW	
CN94	nsp	WAFER, 2P, 7.92mm		CJP02GA89ZY	
BN10	nsp	Wire ass'y (LOCKING TYPE,3P,3		CWB1B00333047001	
BN50	nsp	Wire ass'y (13P,130mm,2.0mm)		CWB1B01313047	
BN51	nsp	WIRE ASSY(LOCK, 7P, 200MM, 2.0		CWB1C00720046001	
BN52	nsp	WIRE ASSY(LOCK, 7P, 200MM, 2.5		CWB1C00718058001	
BN53	nsp	Wire ass'y (9P,260mm,2.0mm)		CWB1B00926047	
BN56	nsp	Wire ass'y (13P,60mm,2.0mm)		CWB1B01306047	
BN58	nsp	WIRE ASSY(11P, 100MM, 2.0MM)		CWB1B01110047	
BN59	nsp	Wire ass'y (5P,80mm,2.0mm)		CWB1B00508047	
BN91	nsp	WIRE ASSY(2P, 300MM, 7.9MM)		CWB4DA32300UZ	
BN92	nsp	Wire ass'y (5P,330mm,2.0mm)		CWB1B00533047	
△ F901,F902	943652500270S	FUSE (217Series, 250V/2.5A)		KBA2C2500A5EY	*
	nsp	HOLDER , FUSE	F901,902	CJFC5S	
JK01,02	90M-YT004860R	JACK, STEREO (BLK MOLD)		CJJ2D008Z	
JK41	943643010130S	JACK, PHONES(6.35mm,GOLD)		CJJ2E020Z	

Ref. No.	Part No.	Part Name	Remarks	Q'ty	New
OL92	943641005850S	JACK , AC OUTLET (230V , 3P)		CJJ7A031Z	
RC51	943262010290S	SENSOR , REMOTE/U		CRVKSM603TH5B	
RY92	00D9430194900	RELAY,G5PA-1,DC6V,1C1P		CSL1E002ZE	
SW51	00D9430194803	SW , PUSH (VERTICAL)		CSH2D013Z	
SW52-54	00D9430199400	SW , PUSH(VERTICAL) CN		KSH2B003Z	
SW91	00D9430140609	EOL item CSH1A010ZV(SDL1P-B)		CSH1A010ZV	
⚠ T901	00D9430193203	TRANSFORMER , SUB	E2	CLT5I008ZE	⚠
⚠ T901	943101005870S	TRANSFORMER , SUB	E1C	CLT5I008ZH	⚠

FRONT PCB ASSY (PMA-520AE)

Ref. No.	Part No.	Part Name	Remarks	Q'ty	New
SEMICONDUCTORS GROUP					
IC12	262010007707S	REMOTE SENSOR , R94EV1A			
IC52	00D9430198207	I.C , OP AMP NJM2068DD			
Q101	00D9430154200	TR KRA102M			
Q500	00D9430154200	TR KRA102M			
Q502	00D9430154404	T.R KTC3198Y			
Q571-576	00D9430107804	TR KRC102M			
Q582,583	00D9430154200	TR KRA102M			
D101	00D9430182609	DIODE , SWITCHING, 1SS133			
D102	963262010460S	L.E.D, SIR-341ST3F			
D500	00D9430182609	DIODE , SWITCHING, 1SS133			
D501	943263100630D	5mm 2 COLOR Red Green LED			*
D571-576	943263100640D	3mm Yellow LED			*
D661-672	00D9430182609	DIODE , SWITCHING, 1SS133			
D941-946	00D9430182502	DIODE , RECT 1N4003			
D951	00D9430182609	DIODE , SWITCHING, 1SS133			
RESISTORS GROUP					
R101	nsp	RES, CARBON(1/5W,1Kohm,J)			
R106,107	nsp	RES, CARBON(1/5W,100ohm,J)			
R503,504	nsp	RES, CARBON(1/5W,150Kohm,J)			
R505,506	nsp	RES, CARBON(1/5W,1Kohm,J)			
R507,508	nsp	RES, CARBON(1/5W,33ohm,J)			
R509,510	nsp	RES, CARBON(1/5W,820ohm,J)			
R511,512	nsp	RES, CARBON(1/5W,7.5Kohm,J)			
R513,514	nsp	RES, CARBON(1/5W,100ohm,J)			
R515,516	nsp	RES, CARBON(1/5W,3.6Kohm,J)			
R519,520	nsp	RES, CARBON(1/5W,3.3Kohm,J)			
R521,522	nsp	RES, CARBON(1/5W,10Kohm,J)			
R523,524	nsp	RES, CARBON(1/5W,470ohm,J)			
R530	nsp	RES, M-OXIDE FILM(1W/220ohm)			
R531,532	nsp	RES, CARBON(1/5W,3.9Kohm,J)			
R533-536	nsp	RES, CARBON(1/5W,330ohm,J)			
R537,538	nsp	RES, CARBON(1/5W,3.6Kohm,J)			
R539,540	nsp	RES, CARBON(1/5W,470ohm,J)			
R541,542	nsp	RES, CARBON(1/5W,4.7Kohm,J)			
R550	nsp	RES, M-OXIDE FILM(1W/220ohm)			
R565,566	nsp	RES, CARBON(1/5W,100ohm,J)			
R567	nsp	RES, CARBON(1/5W,47Kohm,J)			
R568	nsp	RES, CARBON(1/5W,18Kohm,J)			
R569	nsp	RES, CARBON(1/5W,47Kohm,J)			
R571	nsp	RES, CARBON(1/5W,910ohm,J)			
R572	nsp	RES, CARBON(1/5W,1.1Kohm,J)			
R573	nsp	RES, CARBON(1/5W,1.3Kohm,J)			
R574	nsp	RES, CARBON(1/5W,1.6Kohm,J)			
R575	nsp	RES, CARBON(1/5W,2.2Kohm,J)			
R576	nsp	RES, CARBON(1/5W,3Kohm,J)			
R577	nsp	RES, CARBON(1/5W,3.9Kohm,J)			
R578	nsp	RES, CARBON(1/5W,6.8Kohm,J)			
R579	nsp	RES, CARBON(1/5W,10Kohm,J)			
R580	nsp	RES, CARBON(1/5W,20Kohm,J)			
R581	nsp	RES, CARBON(1/5W,62Kohm,J)			
R582	nsp	RES, CARBON(1/5W,10Kohm,J)			
R583	nsp	RES, CARBON(1/5W,22Kohm,J)			
R584	nsp	RES, CARBON(1/5W,220ohm,J)			
R591,592	nsp	RES, CARBON(1/5W,1Kohm,J)			
VR51	00D9430197305	VOLUME , MOTOR			
VR52	00D9430197101	RES , VARIABLE BALANCE			
VR53	00D9430197208	VOLUME , TONE			
VR54	00D9430215504	VOLUME , TONE			
VR56	00D9430195200	SW , ROTARY			

Ref. No.	Part No.	Part Name	Remarks	Q'ty	New
CAPACITORS GROUP					
C127	nsp	CAP , CERAMIC 0.1UF 50V		CCBS1H104ZFT	
C128	nsp	CAP, ELECT(10V/100uF)		CCEA1AH101T	
C481,482	nsp	CAP, MYLAR(50V/1000pF/J)		HCQI1H102JZT	
C503,504	nsp	CAP, ELECT(50V/4.7uF)		CCEA1HH4R7T	
C505-508	nsp	CAP, ELECT(50V/10uF)		CCEA1HH100T	
C509,510	nsp	CAP , MYLAR(50V/0.033uF/J)		CCQI1H333JZT	
C513,514	nsp	CAP, ELECT(50V/0.22uF)		CCEA1HHR22T	
C519,520	nsp	CAP, ELECT(50V/0.1uF)		CCEA1HH0R1T	
C521,522	nsp	CAP, ELECT(50V/0.47uF)		CCEA1HHR47T	
C533,534	nsp	CAP , MYLAR(50V/0.047uF/J)		CCQI1H473JZT	
C535,536	nsp	CAP, ELECT(50V/0.47uF)		CCEA1HHR47T	
C537,538	nsp	CAP , MYLAR(50V/0.033uF/J)		CCQI1H333JZT	
C539,540	nsp	CAP, CERAMIC(50V/39pF/J)		CCCT1H390JC	
C541,542	nsp	CAP, MYLAR(50V/3300pF/J)		HCQI1H332JZT	
C549	nsp	CAP , SEMICONDUCTOR		CCFT1H104ZF	
C565	nsp	CAP, ELECT(16V/100uF)		CCEA1CH101T	
C566	nsp	CAP , SEMICONDUCTOR		CCFT1H104ZF	
C567	nsp	CAP, CERAMIC(50V/47pF/J)		CCCT1H470JC	
C583	nsp	CAP , CERAMIC 0.01uF 50V Z		CCFT1H103ZF	
C591	nsp	CAP, ELECT(50V/22uF)		CCEA1HH220T	
C592	nsp	CAP, MYLAR(50V/0.01uF/J)		HCQI1H103JZT	
C941	943134501920D	CAP , ELECT(25V/1000uF)		CCEA1EH102EC	*
C942	nsp	CAP, ELECT(50V/0.47uF)		CCEA1HHR47T	
C943	nsp	CAP , CERAMIC 0.01uF 50V Z		CCFT1H103ZF	
C944	nsp	CAP , SEMICONDUCTOR		CCFT1H104ZF	
C951	nsp	CAP , CERAMIC(X1/Y2/SC)		KCKDKS472ME	
OTHERS PARTS GROUP					
BN10	nsp	Wire ass'y (LOCKING TYPE,3P,330mm)		CWB1B00333047001	
BN50	nsp	Wire ass'y (13P,130mm,2.0mm)		CWB1B01313047	
BN51	nsp	WIRE ASSY(LOCK, 7P, 200MM, 2.0MM)		CWB1C00720046001	
BN52	nsp	WIRE ASSY(LOCK, 7P, 200MM, 2.5MM)		CWB1C00718058001	
BN53	nsp	Wire ass'y (9P,260mm,2.0mm)		CWB1B00926047	
BN56	nsp	Wire ass'y (13P,60mm,2.0mm)		CWB1B01306047	
BN58	nsp	WIRE ASSY(11P, 100MM, 2.0MM)		CWB1B01110047	
BN59	nsp	Wire ass'y (5P,80mm,2.0mm)		CWB1B00508047	
BN91	nsp	WIRE ASSY(2P, 300MM, 7.9MM)		CWB4DA32300UZ	
BN92	nsp	Wire ass'y (5P,330mm,2.0mm)		CWB1B00533047	
CN10	nsp	LOCKING TYPE , STRAIGHT WAFER , 2MM		CJP03GI236ZW	
CN56	nsp	LOCKING TYPE , STRAIGHT WAFER , 2MM		CJP13GI236ZW	
CN59	nsp	LOCKING TYPE , STRAIGHT WAFER , 2mm		CJP05GI236ZW	
CN90	nsp	WAFER, 2P, 3.96mm		CJP02KA060ZY	
CN91	nsp	WAFER, 2P, 7.92mm		CJP02GA89ZY	
CN92	nsp	LOCKING TYPE , STRAIGHT WAFER , 2mm		CJP05GI236ZW	
CN94	nsp	WAFER, 2P, 7.92mm		CJP02GA89ZY	
⚠ F901,F902	943652500270S	FUSE (217Series, 250V/2.5A)		KBA2C2500A5EY	*
	nsp	HOLDER , FUSE	F901,F902	CJFC5S	
JK01,02	90M-YT004860R	JACK, STEREO (BLK MOLD)		CJJ2D008Z	
JK41	943643010130S	JACK, PHONES(6.35mm,GOLD)		CJJ2E020Z	
RC51	943262010290S	SENSOR , REMOTE/U		CRVKSM603TH5B	
RY92	00D9430194900	RELAY,G5PA-1,DC6V,1C1P		CSL1E002ZE	
SW51	00D9430194803	SW , PUSH (VERTICAL)		CSH2D013Z	
SW52	00D9430199400	SW , PUSH(VERTICAL) CN		KSH2B003Z	
SW91	00D9430140609	EOL item CSH1A010ZV(SDL1P-B)		CSH1A010ZV	
OL91	943641500230D	OUTLET , AC 1P/230V		CJJ7A022Z	*
⚠ T901	00D9430193203	TRANSFORMER , SUB	E2	CLT5I008ZE	⚠
⚠ T901	943101005870S	TRANSFORMER , SUB	E1C	CLT5I008ZH	⚠

MAIN PCB ASSY (PMA-720AE)

Ref. No.	Part No.	Part Name	Remarks	Q'ty	New
SEMICONDUCTORS GROUP					
IC10	00D2630609002	I.C , OP AMP NJM2068DD		HVINJM2068DD	
IC21	00MHC10309030	I.C , FUNCTION		HVILC78212	
IC30	943222500200D	F.E.T , 2SK2145 (N-CH, 2-3L1C, LOW NOISE, TOSHIBA)		CVT2SK2145	*
IC32	943236101330D	IC , SIGNAL LEVEL SENSOR		CVINJU7181RB1	*
IC41	943243101150D	I.C , FLASH(U-COM)		CVIANAM1682A	*
IC42	235810039506D	I.C , MOTER DRIVER(1CHANNEL,SOIC-10NB)		CVILB1930MC	*
IC43	943231101210D	I.C , REGULATOR(SOT-223)		CVIKIA1117BS33	*
IC50	00D2631289900	EOL item I.C , OPAMP(DUAL/LOW NOISE)		CVIAZ4580MTR-E1	
IC91	00D2631100021	I.C,REGULATOR(+8V,T0220IS)		HVIKIA7812API	
IC92	00D2631100018	KIA7806API-U/P			
Q215,216	943216500020S	T.R,RT1N141C(10K-10K)		CVTRT1N141C	
Q251,252	00D9430154404	T.R KTC3198Y		HVTKTC3198YT	
Q253	90M-HT600010R	TR KTA1266Y		HVTKTA1266YT	
Q254	943215500020S	T.R , RT1P141C(10K-10K)		CVTRT1P141C	
Q255,256	00D9430154404	T.R KTC3198Y		HVTKTC3198YT	
Q257	943215500020S	T.R , RT1P141C(10K-10K)		CVTRT1P141C	
Q307-310	943213500150S	TR KSC1845 NPN, TO-92, LOW NOISE, HFE:300-600, FAILCHILD		CVTKSC1845FTA	
Q311-314	943211500150S	TR KSA992 PNP, TO-92, LOW NOISE, HFE:300-600, FAILCHILD		CVTKSA992FTA	
Q315,316	943213500150S	TR KSC1845 NPN, TO-92, LOW NOISE, HFE:300-600, FAILCHILD		CVTKSC1845FTA	
Q317,318	943219005820S	T.R(2SC4495)		CVT2SC4495	
Q319,320	00D9430200700	T.R , POWER 2SD2083P		CVT2SD2083P-OKM	
Q321,322	00D9430197004	T.R , POWER 2SB1383P		CVT2SB1383P-OKM	
Q323,324	943213500150S	T.R , KSC1845 NPN, TO-92, LOW NOISE, HFE:300-600, FAILCHILD		CVTKSC1845FTA	
Q325	943211500150S	TR KSA992 PNP, TO-92, LOW NOISE, HFE:300-600, FAILCHILD		CVTKSA992FTA	
Q331-333	00D9430154404	T.R KTC3198Y		HVTKTC3198YT	
Q408	943216500020S	T.R,RT1N141C(10K-10K)		CVTRT1N141C	
Q420	943216500020S	T.R,RT1N141C(10K-10K)		CVTRT1N141C	
Q421	00D9430154404	T.R KTC3198Y		HVTKTC3198YT	
Q450	90M-HX800090R	T.R , CHIP , SOT-23		HVTKRC111S	
Q452	90M-HX800090R	T.R , CHIP , SOT-23		HVTKRC111S	
Q453	943216500020S	T.R,RT1N141C(10K-10K)		CVTRT1N141C	
Q454	00D9430072502	T.R , CHIP , SOT-23		HVTKTC2875B	
Q456,457	00D9430072502	T.R , CHIP , SOT-23		HVTKTC2875B	
Q464	943216500020S	T.R,RT1N141C(10K-10K)		CVTRT1N141C	
Q465-467	943215500020S	T.R , RT1P141C(10K-10K)		CVTRT1P141C	
Q468	00D9430072502	T.R , CHIP , SOT-23		HVTKTC2875B	
Q469	943216500020S	T.R,RT1N141C(10K-10K)		CVTRT1N141C	
Q471,472	943215500020S	T.R , RT1P141C(10K-10K)		CVTRT1P141C	
Q473	943216500020S	T.R,RT1N141C(10K-10K)		CVTRT1N141C	
Q901	00D2720164004	TR KTD2058Y		HVTKTD2058Y	
Q902	00D2740202001	TR KTB1366Y		HVTKTB1366Y	
Q903,904	943222500210D	F.E.T , 2SK209 (N-CH, TO-236, LOW NOISE, TOSHIBA)		CVT2SK209	*
D132	00MHE20030290	DIODE , BRIDGE 30A		CVDD30XBN20	
D215,216	943209001080S	DIODE , CHIP , SWITCHING 1SS355		CVD1SS355T	
D221,222	943209001080S	DIODE , CHIP , SWITCHING 1SS355		CVD1SS355T	
D309,310	00MHD30271000	DIODE , ZENER ,1/2W, 2.7V		CVDZJ2.7BT	
D311,312	00D9430182609	DIODE , SWITCHING, 1SS133		CVD1SS133MT	
D313,314	00MHD30271000	DIODE , ZENER ,1/2W, 2.7V		CVDZJ2.7BT	
D315,316	00D9430182609	DIODE , SWITCHING, 1SS133		CVD1SS133MT	
D328-330	943209001080S	DIODE , CHIP , SWITCHING 1SS355		CVD1SS355T	
D331-335	00D9430182609	DIODE , SWITCHING, 1SS133		CVD1SS133MT	
D363,364	00D9430182609	DIODE , SWITCHING, 1SS133		CVD1SS133MT	
D401,402	00D9430060501	DIODE , RECTIFIER 1SR159		HVD1SR159-200	
D403	00D9430182502	DIODE , RECT 1N4003		CVD1N4003ST	
D404	00D9430060501	DIODE , RECTIFIER 1SR159		HVD1SR159-200	
D405	00D9430182502	DIODE , RECT 1N4003		CVD1N4003ST	

Ref. No.	Part No.	Part Name	Remarks	Q'ty	New
D406,407	00D9430060501	DIODE , RECTIFIER 1SR159		HVD1SR159-200	
D408	90M-HD302350R	DIODE , ZENER ,1/2W, 27V		CVDZJ27BT	
D409	943202500440D	DIODE , ZENER ,1/2W, 9.1V		CVDZJ9.1BT	*
D410	00D9430182609	DIODE , SWITCHING, 1SS133		CVD1SS133MT	
D421	00D9430060501	DIODE , RECTIFIER 1SR159		HVD1SR159-200	
D458	90M-HZ200190R	DIODE, SWITCHING, SMD TYPE RSL4148		HVDRLS4148SR	
D461	90M-HZ200190R	DIODE, SWITCHING, SMD TYPE RSL4148		HVDRLS4148SR	
D464	90M-HZ200190R	DIODE, SWITCHING, SMD TYPE RSL4148		HVDRLS4148SR	
D901	943447100710D	DIODE HEAT SINK ASSY(CMY2A138)		CVDD30XBN20BI	*
D903,904	943202000940S	DIODE , ZENER ,1/2W, 16V		CVDZJ16BT	
D909,910	00D9430209400	DIODE , RECT 1N4003		CVD1N4003SRT	
D921,922	00D9430182502	DIODE , RECT 1N4003		CVD1N4003T	
D925,926	00D9430209400	DIODE , RECT 1N4003		CVD1N4003SRT	
ZD467	90M-HD302440R	DIODE , ZENER ,1/2W, 4.7V		CVDZJ4.7BT	
RESISTORS GROUP					
R101,102	nsp	RES, CARBON(1/5W,330ohm,J)		CRD20TJ331T	
R103,104	nsp	RES, CARBON(1/5W,150Kohm,J)		CRD20TJ154T	
R105,106	nsp	RES, CARBON(1/5W,68Kohm,J)		CRD20TJ683T	
R109,110	nsp	RES, CARBON(1/5W,220ohm,J)		CRD20TJ221T	
R111,112	nsp	RES, CARBON(1/5W,10Kohm,J)		CRD20TJ103T	
R113,114	nsp	RES, CARBON(1/5W,120Kohm,J)		CRD20TJ124T	
R115,116	nsp	RES, CARBON(1/5W,100ohm,J)		CRD20TJ101T	
R117,118	nsp	RES, CARBON(1/5W,220ohm,J)		CRD20TJ221T	
R119,120	nsp	RES, CARBON(1/5W,47Kohm,J)		CRD20TJ473T	
R123,124	nsp	RES, CARBON(1/5W,220ohm,J)		CRD20TJ221T	
R180	00MNN05470610	RES, CHIP(1608/5%/47ohm)		CRJ10DJ470T	
R190,191	00MNN05470610	RES, CHIP(1608/5%/47ohm)		CRJ10DJ470T	
R192	00MNN05102610	RES, CHIP(1608/5%/1Kohm)		CRJ10DJ102T	
R199,200	nsp	RES, M-OXIDE FILM(1W/4.7ohm)		CRG1SANJ4R7RT	
R201-210	nsp	RES, CARBON(1/5W,220ohm,J)		CRD20TJ221T	
R213,214	nsp	RES, CARBON(1/5W,220ohm,J)		CRD20TJ221T	
R217-219	nsp	RES, CARBON(1/5W,47ohm,J)		CRD20TJ470T	
R220	00MNN05105610	RES, CHIP(1608/5%/1Mohm)		CRJ10DJ105T	
R221-230	nsp	RES, CARBON(1/5W,330Kohm,J)		CRD20TJ334T	
R233,234	nsp	RES, CARBON(1/5W,1Mohm,J)		CRD20TJ105T	
R240	00MNN05223610	RES, CHIP(1608/5%/22Kohm)		CRJ10DJ223T	
R241	00MNN05224610	RES, CHIP(1608/5%/220Kohm)		CRJ10DJ224T	
R251	00MNN05272610	RES, CHIP(1608/5%/2.7Kohm)		CRJ10DJ272T	
R252	00MNN05333610	RES, CHIP(1608/5%/33Kohm)		CRJ10DJ333T	
R253	00MNN05393610	RES, CHIP(1608/5%/39Kohm)		CRJ10DJ393T	
R254,255	nsp	RES, CHIP(1608/5%/10Kohm)		CRJ10DJ103T	
R256,257	00MNN05104610	RES, CHIP(1608/5%/100Kohm)		CRJ10DJ104T	
R258	00MNN05223610	RES, CHIP(1608/5%/22Kohm)		CRJ10DJ223T	
R259	00MNN05102610	RES, CHIP(1608/5%/1Kohm)		CRJ10DJ102T	
R300	00MNN05104610	RES, CHIP(1608/5%/100Kohm)		CRJ10DJ104T	
R301,302	nsp	RES , 1/4W , 1 MOHM , T-TYPE ,		CRD14B2E105JT	*
R303,304	nsp	RES , 1/4W , 220 OHM , T-TYPE		CRD14B2E221JT	*
R305,306	nsp	RES , 1/4W , 8.2 KOHM , T-TYPE		CRD14B2E822JT	*
R307,308	nsp	RES , 1/4W , 270 OHM , T-TYPE		CRD14B2E271JT	*
R309-312	nsp	RES , 1/4W , 4.7 KOHM , T-TYPE		CRD14B2E472JT	*
R313,314	nsp	RES, M-OXIDE FILM(1W/3.9Kohm)		CRG1SANJ392RT	*
R315	00MGD05331160	RES, CARBON(1/5W,330ohm,J)		CRD20TJ331T	
R316-322	nsp	RES, CARBON(1/4W,330ohm,J)		CRD25TJ331T	
R323,324	nsp	RES, CARBON(1/4W,82ohm,J)		CRD25TJ820T	*
R327-330	nsp	RES , 1/4W , 7.5 KOHM , T-TYPE		CRD14B2E752JT	*
R331	nsp	RES, CARBON(1/4W,150ohm,J)		CRD25TJ151T	
R332	00MGD05151160	RES, CARBON(1/5W,150ohm,J)		CRD20TJ151T	
R333	nsp	RES, CARBON(1/4W,150ohm,J)		CRD25TJ151T	
R334	00MGD05151160	RES, CARBON(1/5W,150ohm,J)		CRD20TJ151T	
R335	nsp	RES, 1/4W, 12KOHM,T-TYPE		CRD14B2E123JT	
R337	nsp	RES, 1/4W, 3.9KOHM,T-TYPE		CRD14B2E392JT	
R338	nsp	RES, 1/4W, 12KOHM,T-TYPE		CRD14B2E123JT	
R340	nsp	RES , 1/4W , 1 MOHM , T-TYPE ,		CRD14B2E105JT	

Ref. No.	Part No.	Part Name	Remarks	Q'ty	New
R342	nsp	RES , 1/4W , 150 OHM , T-TYPE			
R343,344	00D9430101101	WIRE ,COPPER SN95/PB5, 0.6			
R349-356	943124500330D	RES, M-OXIDE FILM(2W/0.22ohm)			
R360	nsp	RES , 1/4W , 1 MOHM , T-TYPE ,			
R361,362	nsp	RES, CARBON(1/4W,22Kohm,J)			
R363,364	00MGD05274160	RES, CARBON(1/5W,270Kohm,J)			
R365,366	00MGD05223160	RES, CARBON(1/5W,22Kohm,J)			
R367	00MGD05473160	RES, CARBON(1/5W,47Kohm,J)			
R368	nsp	RES, CARBON(1/5W,12Kohm,J)			
R369,370	nsp	RES, CARBON(1/5W,22Kohm,J)			
R375,376	nsp	RES, CARBON(1/5W,39Kohm,J)			
R377,378	00MGD05104160	RES, CARBON(1/5W,100Kohm,J)			
R379	00MGD05103160	RES, CARBON(1/5W,10Kohm,J)			
R380	nsp	RES , 1/4W , 27 KOHM , T-TYPE			
R381,382	nsp	RES, M-OXIDE FILM(1W/390ohm)			
R383,384	00MGD05391160	RES, CARBON(1/5W,390ohm,J)			
R385,386	00MGD05103160	RES, CARBON(1/5W,10Kohm,J)			
R387,388	00MGD05104160	RES, CARBON(1/5W,100Kohm,J)			
R389,390	00MGD05223160	RES, CARBON(1/5W,22Kohm,J)			
R391	00MGD05103160	RES, CARBON(1/5W,10Kohm,J)			
R392	nsp	RES , 1/4W , 2.2 KOHM , T-TYPE			
R393-396	00MGD05103160	RES, CARBON(1/5W,10Kohm,J)			
R397	nsp	RES , 1/4W , 150 OHM , T-TYPE			
R398,399	nsp	RES, M-OXIDE FILM(1W/4.7ohm)			
R400	nsp	RES , 1/4W , 27 KOHM , T-TYPE			
R401	00MNN05105610	RES, CHIP(1608/5%/1Mohm)			
R402	nsp	RES , 1/4W , 2.2 KOHM , T-TYPE			
R403,404	00MNN05102610	RES, CHIP(1608/5%/1Kohm)			
R405	00MNN05104610	RES, CHIP(1608/5%/100Kohm)			
R406-409	00MNN05223610	RES, CHIP(1608/5%/22Kohm)			
R410,411	00MNN05102610	RES, CHIP(1608/5%/1Kohm)			
R412-414	nsp	RES, CHIP(1608/5%/0ohm)			
R415	nsp	RES, 1/4W, 3.9KOHM,T-TYPE			
R418	00MNN05102610	RES, CHIP(1608/5%/1Kohm)			
R419,420	nsp	RES, CHIP(1608/5%/10Kohm)			
R421,422	00MNN05102610	RES, CHIP(1608/5%/1Kohm)			
R425,426	00MNN05104610	RES, CHIP(1608/5%/100Kohm)			
R428,429	00MNN05102610	RES, CHIP(1608/5%/1Kohm)			
R430,431	00MNN05104610	RES, CHIP(1608/5%/100Kohm)			
R433	00MNN05102610	RES, CHIP(1608/5%/1Kohm)			
R441	nsp	RES, CHIP(1608/5%/4.7Kohm)			
R442	00MNN05331610	RES, CHIP(1608/5%/330ohm)			
R443	00MNN05223610	RES, CHIP(1608/5%/22Kohm)			
R444,445	00MNN05104610	RES, CHIP(1608/5%/100Kohm)			
R446	nsp	RES, CHIP(1608/5%/4.7Kohm)			
R448	00MNN05223610	RES, CHIP(1608/5%/22Kohm)			
R451,452	00MNN05821610	RES, CHIP(1608/5%/820ohm)			
R453	nsp	RES, CHIP(1608/5%/10Kohm)			
R454	00MNN05473610	RES, CHIP(1608/5%/47Kohm)			
R456	00MNN05102610	RES, CHIP(1608/5%/1Kohm)			
R457	00MNN05224610	RES, CHIP(1608/5%/220Kohm)			
R458	00MNN05102610	RES, CHIP(1608/5%/1Kohm)			
R459	nsp	RES, CHIP(1608/5%/10Kohm)			
R460	nsp	RES, CHIP(1608/5%/0ohm)			
R461	nsp	RES, CHIP(1608/5%/10Kohm)			
R462,463	00MNN05101610	RES, CHIP(1608/5%/100ohm)			
R464	nsp	RES, CHIP(1608/5%/10Kohm)			
R465	00MNN05221610	RES, CHIP(1608/5%/220ohm)			
R466	00MNN05222610	RES, CHIP(1608/5%/2.2Kohm)			
R467	00MNN05223610	RES, CHIP(1608/5%/22Kohm)			
R469,470	00MNN05473610	RES, CHIP(1608/5%/47Kohm)			
R471	00MNN05102610	RES, CHIP(1608/5%/1Kohm)			
R473	nsp	RES, CHIP(1608/5%/0ohm)			
R480	00MNN05223610	RES, CHIP(1608/5%/22Kohm)			
R481	00MNN05104610	RES, CHIP(1608/5%/100Kohm)			
R483-488	00MNN05203610	RES, CHIP(1608/5%/20Kohm)			

Ref. No.	Part No.	Part Name	Remarks	Q'ty	New
R489	nsp	RES, CHIP(1608/5%/10Kohm)		CRJ10DJ103T	
R490	00MNN05104610	RES, CHIP(1608/5%/100Kohm)		CRJ10DJ104T	
R491	nsp	RES, CHIP(1608/5%/10Kohm)		CRJ10DJ103T	
R492,493	00MNN05473610	RES, CHIP(1608/5%/47Kohm)		CRJ10DJ473T	
R495-500	00MNN05102610	RES, CHIP(1608/5%/1Kohm)		CRJ10DJ102T	
R501	00MGD05104160	RES, CARBON(1/5W,100Kohm,J)		CRD20TJ104T	
R502	nsp	RES, CHIP(1608/5%/4.7Kohm)		CRJ10DJ472T	
R510	00MGD05103160	RES, CARBON(1/5W,10Kohm,J)		CRD20TJ103T	
R550	nsp	RES, CARBON(1/4W,4.7Kohm,J)		CRD25TJ472T	
R551	00MGD05473160	RES, CARBON(1/5W,47Kohm,J)		CRD20TJ473T	
R552	nsp	RES, CARBON(1/4W,47Kohm,J)		CRD25TJ473T	
R553	00MGD05472160	RES, CARBON(1/5W,4.7Kohm,J)		CRD20TJ472T	
R554	00MGD05473160	RES, CARBON(1/5W,47Kohm,J)		CRD20TJ473T	
R555	00MGD05472160	RES, CARBON(1/5W,4.7Kohm,J)		CRD20TJ472T	
R600,601	00MNN05470610	RES, CHIP(1608/5%/47ohm)		CRJ10DJ470T	
R602,603	00MNN05102610	RES, CHIP(1608/5%/1Kohm)		CRJ10DJ102T	
R604,605	00MGD05104160	RES, CARBON(1/5W,100Kohm,J)		CRD20TJ104T	
R710,711	nsp	RES, CHIP(1608/5%/0ohm)		CRJ10DJ0R0T	
R750	00MNN05223610	RES, CHIP(1608/5%/22Kohm)		CRJ10DJ223T	
R910	00MGD05103160	RES, CARBON(1/5W,10Kohm,J)		CRD20TJ103T	
VR31,32	943161100150D	RES SEMI FIXED(4.7K,B CURVE)		CVN1GE472B01T	*
CAPACITORS GROUP					
C101-104	nsp	CAP, CERAMIC(50V/100pF/K)		CCKT1H101KB	
C105,106	nsp	CAP, ELECT(50V/10uF)		CCEA1HH100T	
C109,110	943134010570S	CAP, ELECT(16V/220uF)		CCEA1CH221T	
C111,112	943139001260S	EOL item CAP, MYLAR(50V/6800pF/J)		HCQI1H682JZT	
C113,114	nsp	CAP, MYLAR(50V/0.018pF/J)		HCQI1H183JZT	
C115,116	943139001260S	EOL item CAP, MYLAR(50V/6800pF/J)		HCQI1H682JZT	
C117,118	nsp	CAP, ELECT(50V/10uF)		CCEA1HH100T	
C119,120	nsp	CAP, MYLAR(50V/3900pF/J)		HCQI1H392JZT	
C121,122	00D2544569924	CAP, ELECT(ELNA, 6.3X11, RA3-25V 101MF3#8P-T2)		CCEA1ERA38P101T	
C215,216	00D2544702956	CAP, ELECT(ELNA,8X12,RFS-50V 100MG3#A-F1)		CCEA1HRFSA100E	
C220	943134010590S	CAP, ELECT(50V/22uF)		CCEA1HH220T	
C221	00D2544569924	CAP, ELECT(ELNA, 6.3X11, RA3-25V 101MF3#8P-T2)		CCEA1ERA38P101T	
C223	00D2544569924	CAP, ELECT(ELNA, 6.3X11, RA3-25V 101MF3#8P-T2)		CCEA1ERA38P101T	
C224	nsp	CAP, CHIP(1608, 50V/10pF)		CCUS1H100JA	
C225	nsp	CAP, ELECT(50V/10uF)		CCEA1HH100T	
C230	nsp	CAP, CHIP(1608, 50V/1000pF)		CCUS1H102KC	
C251	nsp	CAP, ELECT(50V/33uF)		CCEA1HH330T	
C252	nsp	CAP, CHIP(1608, 50V/0.022uF)		CCUS1H223KC	
C254	nsp	CAP, CHIP(1608, 50V/0.047uF)		CCUS1H473KC	
C256	00D9430175001	CAP, ELECT(25V/47uF)		CCEA1EH470T	
C258	943134006150S	CAP, ELECT(10V/470uF),8X11.5L,RA3,ELNA		CCEA1ARA38P471T	
C303,304	nsp	CAP, POLYPROPYLENE(FNS(135)-1		CCMP2A471JS13T	*
C305,306	nsp	CAP, POLYPROPYLENE(FAS(133)-2		CCMP2B101KS17T	*
C307,308	nsp	CAP,POLYPROPYLENE(FNS(135)-100		CCMP2A102JS13T	*
C309-312	00D2544774719	CAP, ELECT (220uF/25V,12.5X20, ELNA RFS)		CCEA1ERFSA221E	
C319-322	943133501450D	CAP, FNS (135)-100VDC-222J		CCMP2A222JS13T	*
C325,326	nsp	CAP, POLYPROPYLENE(FAS(135)-2		CCMP2B220KS17T	*
C327,328	nsp	CAP, POLYPROPYLENE(SEORYONG,		CCMP2A102JR16T	*
C329,330	00D2544703751	CAP, ELECT(ELNA, 10X12.5, RFS-50V 220MH3#A-F)		CCEA1HRFSA220E	
C331	943133501470D	CAP, FNS (135)-100VDC-103J		CCMP2A103JS13T	*
C340	nsp	CAP, POLYESTER FILM(SEORYONG,PPF A 224 J 100V)		CCMP2A224JR11T	
C341,342	133050078465S	CAP, POLYPROPYLENE(FAS(135)-2		CQ93P2D330K(FAS)	*
C346	943133501470D	CAP, FNS (135)-100VDC-103J		CCMP2A103JS13T	*
C347	nsp	CAP, POLYESTER FILM(SEORYONG,PPF A 224 J 100V)		CCMP2A224JR11T	
C367	nsp	CAP, ELECT(50V/4.7uF)		CCEA1HH4R7T	
C375-378	nsp	CAP, POLYPROPYLENE(SEORYONG,		CCMP2A103JR16T	*

Ref. No.	Part No.	Part Name	Remarks	Q'ty	New
C379,380	nsp	CAP , POLYPROPYLENE(SEORYONG,		CCMP2A104JR16T	*
C383,384	00D2544569924	CAP , ELECT(ELNA, 6.3X11, RA3-25V 101MF3#8P-T2)		CCEA1ERA38P101T	
C390-392	nsp	CAP , POLYPROPYLENE(SEORYONG,		CCMP2A102JR16T	*
C393-396	nsp	CAP , POLYPROPLENE(SEORYONG,PP		CCMP2A153JR16T	*
C401	nsp	CAP, ELECT(16V/100uF)		CCEA1CH101T	
C402	nsp	CAP, CHIP(1608, 50V/0.01uF)		CCUS1H103KC	
C403	nsp	CAP, ELECT(16V/100uF)		CCEA1CH101T	
C404	nsp	CAP, CHIP(1608, 50V/0.01uF)		CCUS1H103KC	
C405	943134010600S	CAP, ELECT(16V/3300uF)		CCEA1CH332E	
C406	943134010590S	CAP, ELECT(50V/22uF)		CCEA1HH220T	
C407,408	nsp	CAP, CHIP(1608, 50V/0.01uF)		CCUS1H103KC	
C421	nsp	CAP, ELECT(50V/10uF)		CCEA1HH100T	
C445	nsp	CAP, CHIP(1608, 50V/0.1uF)		CCUS1H104KC	
C458	nsp	CAP, ELECT(50V/2.2uF)		CCEA1HH2R2T	
C461	nsp	CAP, CHIP(1608, 50V/0.01uF)		CCUS1H103KC	
C464	nsp	CAP, ELECT(50V/1uF)		CCEA1HH1R0T	
C465	nsp	CAP, ELECT(50V/10uF)		CCEA1HH100T	
C466	00D9430173508	CAP, ELECT(10V/470uF)		CCEA1AH471T	
C486-489	nsp	CAP, CHIP(1608, 50V/0.01uF)		CCUS1H103KC	
C492	nsp	CAP, CHIP(1608, 50V/0.047uF)		CCUS1H473KC	
C493	00D9430175001	CAP , ELECT(25V/47uF)		CCEA1EH470T	
C494,495	nsp	CAP, ELECT(50V/10uF)		CCEA1HH100T	
C500	nsp	CAP, ELECT(50V/2.2uF)		CCEA1HH2R2T	
C600-602	nsp	CAP, ELECT(50V/10uF)		CCEA1HH100T	
C901,902	00D2546262009	CPA , ELECT (8200uF/56V, 30X63		CCET56VLAO822NZ	
C903,904	90M-OF100490R	CAP, METAL PE FILM(250V/0.1uF)		KCME2E104JP04T	
C907,908	00D2544702956	CAP , ELECT(ELNA,8X12,RFS-50V 100MG3#A-F1)		CCEA1HRFSA100E	
C909,910	00D2544664706	CAP , ELECT(ELNA, 12.5X25, RFS-63V 101MI6#A-F)		CCEA1JRFSA101E	
C921,922	nsp	CAP , POLYPROPYLENE(SEORYONG,		CCMP2A103JR16T	*
C923	nsp	CAP , ELECT(25V/1000uF)		CCEA1EH102E	*
C925,926	nsp	CAP , POLYPROPYLENE(SEORYONG,		CCMP2A103JR16T	*
C929,930	00D2544703777	CAP , ELECT (47uF/50V,10X16, ELNA RFS)		CCEA1HRFSA470T	
OTHERS PARTS GROUP					
CN31,32	nsp	WAFER/STRAIGHT/2.5mm/3P		CJP03GA01ZY	
CN41	nsp	WAFER , STRAIGHT(DVD LOADER)		CJP06GA19ZY	
CN50	nsp	LOCKING TYPE , STRAIGHT WAFER/2mm		CJP13GI236ZW	
CN51	nsp	LOCKING TYPE , STRAIGHT WAFER/2mm		CJP07GI236ZW	
CN52	nsp	LOCKING TYPE , STRAIGHT WAFER,		CJP07GI237ZW	
CN53	nsp	LOCKING TYPE , STRAIGHT WAFER		CJP09GI236ZW	
CN58	nsp	LOCKING TYPE , STRAIGHT WAFER/2mm		CJP11GI236ZW	
CN93	nsp	LOCKING TYPE , STRAIGHT WAFER,3PIN 2.5MM		CJP03GI237ZW	
CN95	nsp	WAFER,YW396-03B(3.96mm)		CJP03GA90ZY	
⚠ F801-804	90M-FS001520R	FUSE(1A, 372 SERIES/TR5)		KBA2D1000A3EYT	
JK11	00D9430191700	2P JACK , IN/OUT		CJJ4N034Z	
JK21,22	943643101860D	RCA , JACK BOARD (WWW/RRR,6P)		CJJ4R058Z	*
JK24	00D9430191700	JACK , IN/OUT		CJJ4N034Z	
JK31	943643003280S	TERMINAL , 8P SPEAKER(SCREW, RD/BK/BK/ RD)		CJJ5Q020Z	
L101,102	00D9430193601	COIL, TOROIDAL		CLU9S004Z	
RY31	943682000810S	RELAY,BC3-12H,DC12V,2C2P		CSL4A016ZU	
RY32,33	943682010300S	RELAY,G5PA-28-MC,DC12V,2C1P		CSL3A018ZE	
RY51,52	943682000810S	RELAY,BC3-12H,DC12V,2C2P		CSL4A016ZU	
TH51	00D9430194502	THERMISTOR ASS'Y(170MM)		CRT0217025MM	
X401	nsp	RESONATOR , CERAMIC (8Mhz,15pF)		CVFCSTLS8M00G53A0T	*
	nsp	HEAT SINK		CMY2A138	
	nsp	COMPOUND , SILICONE		K8AYG6260	

Ref. No.	Part No.	Part Name	Remarks	Q'ty	New
	nsp	HEAT SINK , TR		CMY1A043	
	00D2631100018	I.C,REGULATOR(+6V,T0220IS)		HVIKIA7806API	
	00D9430194609	POSISTOR		CRTPTFM04BB222Q	

MAIN PCB ASSY (PMA-520AE)

Ref. No.	Part No.	Part Name	Remarks	Q'ty	New
SEMICONDUCTORS GROUP					
IC10	00D9430198207	I.C , OP AMP		HVINJM2068DD	
IC21	00MHC10309030	I.C , FUNCTION		HVILC78212	
IC30	943222500200D	F.E.T , 2SK2145 (N-CH, 2-3L1C, LOW NOISE, TOSHIBA)		CVT2SK2145	*
IC32	943236101330D	IC , SIGNAL LEVEL SENSOR		CVINJU7181RB1	*
IC41	943243101150D	I.C , FLASH(U-COM)		CVIANAM1682A	*
IC42	235810039506D	I.C , MOTER DRIVER(1CHANNEL,SOIC-10NB)		CVILB1930MC	
IC43	943231101210D	I.C , REGULATOR(SOT-223)		CVIKIA1117BS33	*
IC50	00D2631289900	EOL item I.C , OPAMP(DUAL/LOW NOISE)		CVIAZ4580MTR-E1	
IC91	00D2631100021	I.C,REGULATOR(+8V,T0220IS)		HVIKIA7812API	
IC92	00D2631100018	KIA7806API-U/P			
Q215,216	943216500020S	T.R,RT1N141C(10K-10K)		CVTRT1N141C	
Q251,252	00D9430154404	TR KTC3198Y		HVTKTC3198YT	
Q253	90M-HT600010R	TR KTA1266Y		HVTKTA1266YT	
Q254	943215500020S	T.R , RT1P141C(10K-10K)		CVTRT1P141C	
Q255,256	00D9430154404	TR KTC3198Y		HVTKTC3198YT	
Q257	943215500020S	T.R , RT1P141C(10K-10K)		CVTRT1P141C	
Q307-310	943213500150S	TR KSC1845 NPN, TO-92, LOW NOISE, HFE:300-600, FAILCHILD		CVTKSC1845FTA	
Q311-314	943211500150S	TR KSA992 PNP, TO-92, LOW NOISE, HFE:300-600, FAILCHILD		CVTKSA992FTA	
Q315,316	943213500150S	TR KSC1845 NPN, TO-92, LOW NOISE, HFE:300-600, FAILCHILD		CVTKSC1845FTA	
Q317,318	943219005820S	T.R(2SC4495)		CVT2SC4495	
Q319,320	00D9430200700	T.R , POWER 2SD2083P		CVT2SD2083P-OKM	
Q321,322	00D9430197004	T.R , POWER 2SB1383P		CVT2SB1383P-OKM	
Q323,324	943213500150S	T.R , KSC1845 NPN, TO-92, LOW NOISE, HFE:300-600, FAILCHILD		CVTKSC1845FTA	
Q325	943211500150S	TR KSA992 PNP, TO-92, LOW NOISE, HFE:300-600, FAILCHILD		CVTKSA992FTA	
Q332,333	00D9430154404	TR KTC3198Y		HVTKTC3198YT	
Q408	943216500020S	T.R,RT1N141C(10K-10K)		CVTRT1N141C	
Q420	943216500020S	T.R,RT1N141C(10K-10K)		CVTRT1N141C	
Q421	00D9430154404	TR KTC3198Y		HVTKTC3198YT	
Q450	90M-HX800090R	T.R , CHIP , SOT-23		HVTKRC111S	
Q452	90M-HX800090R	T.R , CHIP , SOT-23		HVTKRC111S	
Q453	943216500020S	T.R,RT1N141C(10K-10K)		CVTRT1N141C	
Q454	00D9430072502	T.R , CHIP , SOT-23		HVTKTC2875B	
Q456,457	00D9430072502	T.R , CHIP , SOT-23		HVTKTC2875B	
Q464	943216500020S	T.R,RT1N141C(10K-10K)		CVTRT1N141C	
Q465-467	943215500020S	T.R , RT1P141C(10K-10K)		CVTRT1P141C	
Q468	00D9430072502	T.R , CHIP , SOT-23		HVTKTC2875B	
Q469	943216500020S	T.R,RT1N141C(10K-10K)		CVTRT1N141C	
Q471,472	943215500020S	T.R , RT1P141C(10K-10K)		CVTRT1P141C	
Q473	943216500020S	T.R,RT1N141C(10K-10K)		CVTRT1N141C	
Q901	00D2720164004	TR KTD2058Y		HVTKTD2058Y	
Q902	00D2740202001	TR KTB1366Y		HVTKTB1366Y	
Q903,904	943222500210D	F.E.T , 2SK209 (N-CH, TO-236, LOW NOISE, TOSHIBA)		CVT2SK209	*
D132	00MHE20030290	DIODE, BRIDGE 30A		CVDD30XBN20	
D215,216	943209001080S	DIODE , CHIP , SWITCHING 1SS355		CVD1SS355T	
D221,222	943209001080S	DIODE , CHIP , SWITCHING 1SS355		CVD1SS355T	
D309,310	00MHD30271000	DIODE , ZENER ,1/2W, 2.7V		CVDZJ2.7BT	
D311,312	00D9430182609	DIODE , SWITCHING, 1SS133		CVD1SS133MT	
D313,314	00MHD30271000	DIODE , ZENER ,1/2W, 2.7V		CVDZJ2.7BT	
D315,316	00D9430182609	DIODE , SWITCHING, 1SS133		CVD1SS133MT	
D329,330	943209001080S	DIODE , CHIP , SWITCHING 1SS355		CVD1SS355T	
D331-335	00D9430182609	DIODE , SWITCHING, 1SS133		CVD1SS133MT	
D363,364	00D9430182609	DIODE , SWITCHING, 1SS133		CVD1SS133MT	
D401,402	90M-HD201840R	DIODE , RECTIFIER 1SR159		HVD1SR159-200	
D403	00D9430182502	DIODE , RECT 1N4003		CVD1N4003ST	
D404	90M-HD201840R	DIODE , RECTIFIER 1SR159		HVD1SR159-200	

Ref. No.	Part No.	Part Name	Remarks	Q'ty	New
D405	00D9430182502	DIODE , RECT 1N4003		CVD1N4003ST	
D406,407	90M-HD201840R	DIODE , RECTIFIER 1SR159		HVD1SR159-200	
D408	90M-HD302350R	DIODE , ZENER ,1/2W, 27V		CVDZJ27BT	
D409	943202500440D	DIODE , ZENER ,1/2W, 9.1V		CVDZJ9.1BT	*
D410	00D9430182609	DIODE , SWITCHING, 1SS133		CVD1SS133MT	
D421	90M-HD201840R	DIODE , RECTIFIER 1SR159		HVD1SR159-200	
D458	90M-HZ200190R	DIODE, SWITCHING, SMD TYPE RSL4148		HVDRLS4148SR	
D461	90M-HZ200190R	DIODE, SWITCHING, SMD TYPE RSL4148		HVDRLS4148SR	
D464	90M-HZ200190R	DIODE, SWITCHING, SMD TYPE RSL4148		HVDRLS4148SR	
D901	943447100710D	DIODE HEAT SINK ASS'Y(CMY2A138)		CVDD30XBN20BI	*
D903,904	943202000940S	DIODE , ZENER ,1/2W, 16V		CVDZJ16BT	
D909,910	00D9430209400	DIODE , RECT 1N4003		CVD1N4003SRT	
D921,922	00D9430182502	DIODE , RECT 1N4003		CVD1N4003T	
D925,926	00D9430209400	DIODE , RECT 1N4003		CVD1N4003SRT	
ZD46	90M-HD302440R	DIODE , ZENER ,1/2W, 4.7V		CVDZJ4.7BT	
RESISTORS GROUP					
R101,102	nsp	RES, CARBON(1/5W,330ohm,J)		CRD20TJ331T	
R103,104	nsp	RES, CARBON(1/5W,150Kohm,J)		CRD20TJ154T	
R105,106	nsp	RES, CARBON(1/5W,68Kohm,J)		CRD20TJ683T	
R109,110	nsp	RES, CARBON(1/5W,220ohm,J)		CRD20TJ221T	
R111,112	nsp	RES, CARBON(1/5W,10Kohm,J)		CRD20TJ103T	
R113,114	nsp	RES, CARBON(1/5W,120Kohm,J)		CRD20TJ124T	
R115,116	nsp	RES, CARBON(1/5W,100ohm,J)		CRD20TJ101T	
R117,118	nsp	RES, CARBON(1/5W,220ohm,J)		CRD20TJ221T	
R119,120	nsp	RES, CARBON(1/5W,47Kohm,J)		CRD20TJ473T	
R123,124	nsp	RES, CARBON(1/5W,220ohm,J)		CRD20TJ221T	
R180	nsp	RES, CHIP(1608/5%/47ohm)		CRJ10DJ470T	
R190,191	nsp	RES, CHIP(1608/5%/47ohm)		CRJ10DJ470T	
R192	nsp	RES, CHIP(1608/5%/1Kohm)		CRJ10DJ102T	
R199,200	nsp	RES, M-OXIDE FILM(1W/4.7ohm)		CRG1SANJ4R7RT	
R201-210	nsp	RES, CARBON(1/5W,220ohm,J)		CRD20TJ221T	
R213,214	nsp	RES, CARBON(1/5W,220ohm,J)		CRD20TJ221T	
R217-219	nsp	RES, CARBON(1/5W,47ohm,J)		CRD20TJ470T	
R220	nsp	RES, CHIP(1608/5%/1Mohm)		CRJ10DJ105T	
R221-230	nsp	RES, CARBON(1/5W,330Kohm,J)		CRD20TJ334T	
R233,234	nsp	RES, CARBON(1/5W,1Mohm,J)		CRD20TJ105T	
R240	nsp	RES, CHIP(1608/5%/22Kohm)		CRJ10DJ223T	
R241	nsp	RES, CHIP(1608/5%/220Kohm)		CRJ10DJ224T	
R251	nsp	RES, CHIP(1608/5%/2.7Kohm)		CRJ10DJ272T	
R252	nsp	RES, CHIP(1608/5%/33Kohm)		CRJ10DJ333T	
R253	nsp	RES, CHIP(1608/5%/39Kohm)		CRJ10DJ393T	
R254,255	nsp	RES, CHIP(1608/5%/10Kohm)		CRJ10DJ103T	
R256,257	nsp	RES, CHIP(1608/5%/100Kohm)		CRJ10DJ104T	
R258	nsp	RES, CHIP(1608/5%/22Kohm)		CRJ10DJ223T	
R259	nsp	RES, CHIP(1608/5%/1Kohm)		CRJ10DJ102T	
R301,302	nsp	RES, CARBON(1/4W,1Mohm,J)		CRD25TJ105T	
R303,304	nsp	RES, CARBON(1/4W,220ohm,J)		CRD25TJ221T	
R305,306	nsp	RES, CARBON(1/4W,8.2Kohm,J)		CRD25TJ822T	
R307,308	nsp	RES, CARBON(1/4W,270ohm,J)		CRD25TJ271T	
R309-312	nsp	RES, CARBON(1/4W,4.7Kohm,J)		CRD25TJ472T	
R313,314	nsp	RES, M-OXIDE FILM(1W/3.9Kohm)		CRG1SANJ392RT	
R315	nsp	RES, CARBON(1/5W,330ohm,J)		CRD20TJ331T	
R316-322	nsp	RES, CARBON(1/4W,330ohm,J)		CRD25TJ331T	
R323,324	nsp	RES, CARBON(1/4W,82ohm,J)		CRD25TJ820T	
R327-330	nsp	RES, CARBON(1/4W,7.5Kohm,J)		CRD25TJ752T	
R331-334	nsp	RES, CARBON(1/4W,150ohm,J)		CRD25TJ151T	
R335	nsp	RES, CARBON(1/5W,12Kohm,J)		CRD20TJ123T	
R337	nsp	RES, CARBON(1/4W,3.9Kohm,J)		CRD25TJ392T	
R338	nsp	RES, CARBON(1/5W,12Kohm,J)		CRD20TJ123T	
R340	nsp	RES, CARBON(1/4W,1Mohm,J)		CRD25TJ105T	
R342	nsp	RES, CARBON(1/4W,150ohm,J)		CRD25TJ151T	
R349-356	943124500330D	RES, M-OXIDE FILM(2W/0.22ohm)		CRG2SANJR22RT	*
R360	nsp	RES, CARBON(1/4W,1Mohm,J)		CRD25TJ105T	

Ref. No.	Part No.	Part Name	Remarks	Q'ty	New
R361,362	nsp	RES, CARBON(1/4W,22Kohm,J)		CRD25TJ223T	
R363,364	nsp	RES, CARBON(1/5W,270Kohm,J)		CRD20TJ274T	
R365,366	nsp	RES, CARBON(1/5W,22Kohm,J)		CRD20TJ223T	
R367	nsp	RES, CARBON(1/5W,47Kohm,J)		CRD20TJ473T	
R368	nsp	RES, CARBON(1/5W,12Kohm,J)		CRD20TJ123T	
R369,370	nsp	RES, CARBON(1/5W,22Kohm,J)		CRD20TJ223T	
R375,376	nsp	RES, CARBON(1/5W,39Kohm,J)		CRD20TJ393T	
R377,378	nsp	RES, CARBON(1/5W,100Kohm,J)		CRD20TJ104T	
R379	nsp	RES, CARBON(1/5W,10Kohm,J)		CRD20TJ103T	
R380	nsp	RES, CARBON(1/4W,27Kohm,J)		CRD25TJ273T	
R381,382	nsp	RES, M-OXIDE FILM(1W/390ohm)		CRG1SANJ391RT	
R389,390	nsp	RES, CARBON(1/5W,22Kohm,J)		CRD20TJ223T	
R391	nsp	RES, CARBON(1/5W,10Kohm,J)		CRD20TJ103T	
R392	nsp	RES, CARBON(1/4W,2.2Kohm,J)		CRD25TJ222T	
R393-396	nsp	RES, CARBON(1/5W,10Kohm,J)		CRD20TJ103T	
R397	nsp	RES, CARBON(1/4W,150ohm,J)		CRD25TJ151T	
R398,399	nsp	RES, M-OXIDE FILM(1W/4.7ohm)		CRG1SANJ47RT	
R400	nsp	RES, CARBON(1/4W,27Kohm,J)		CRD25TJ273T	
R401	nsp	RES, CHIP(1608/5%/1Mohm)		CRJ10DJ105T	
R402	nsp	RES, CARBON(1/5W,2.2Kohm,J)		CRD20TJ222T	
R403,404	nsp	RES, CHIP(1608/5%/1Kohm)		CRJ10DJ102T	
R405	nsp	RES, CHIP(1608/5%/100Kohm)		CRJ10DJ104T	
R406-409	nsp	RES, CHIP(1608/5%/22Kohm)		CRJ10DJ223T	
R410,411	nsp	RES, CHIP(1608/5%/1Kohm)		CRJ10DJ102T	
R412-414	nsp	RES, CHIP(1608/5%/0ohm)		CRJ10DJ0R0T	
R415	nsp	RES, CARBON(1/5W,3.9Kohm,J)		CRD20TJ392T	
R418	nsp	RES, CHIP(1608/5%/1Kohm)		CRJ10DJ102T	
R419,420	nsp	RES, CHIP(1608/5%/10Kohm)		CRJ10DJ103T	
R421,422	nsp	RES, CHIP(1608/5%/1Kohm)		CRJ10DJ102T	
R425,426	nsp	RES, CHIP(1608/5%/100Kohm)		CRJ10DJ104T	
R428,429	nsp	RES, CHIP(1608/5%/1Kohm)		CRJ10DJ102T	
R430,431	nsp	RES, CHIP(1608/5%/100Kohm)		CRJ10DJ104T	
R433	nsp	RES, CHIP(1608/5%/1Kohm)		CRJ10DJ102T	
R441	nsp	RES, CHIP(1608/5%/4.7Kohm)		CRJ10DJ472T	
R442	nsp	RES, CHIP(1608/5%/330ohm)		CRJ10DJ331T	
R443	nsp	RES, CHIP(1608/5%/22Kohm)		CRJ10DJ223T	
R444,445	nsp	RES, CHIP(1608/5%/100Kohm)		CRJ10DJ104T	
R446	nsp	RES, CHIP(1608/5%/4.7Kohm)		CRJ10DJ472T	
R448	nsp	RES, CHIP(1608/5%/22Kohm)		CRJ10DJ223T	
R451,452	nsp	RES, CHIP(1608/5%/820ohm)		CRJ10DJ821T	
R453	nsp	RES, CHIP(1608/5%/10Kohm)		CRJ10DJ103T	
R454	nsp	RES, CHIP(1608/5%/47Kohm)		CRJ10DJ473T	
R456	nsp	RES, CHIP(1608/5%/1Kohm)		CRJ10DJ102T	
R457	nsp	RES, CHIP(1608/5%/220Kohm)		CRJ10DJ224T	
R458	nsp	RES, CHIP(1608/5%/1Kohm)		CRJ10DJ102T	
R459	nsp	RES, CHIP(1608/5%/10Kohm)		CRJ10DJ103T	
R460	nsp	RES, CHIP(1608/5%/0ohm)		CRJ10DJ0R0T	
R461	nsp	RES, CHIP(1608/5%/10Kohm)		CRJ10DJ103T	
R462,463	nsp	RES, CHIP(1608/5%/100ohm)		CRJ10DJ101T	
R464	nsp	RES, CHIP(1608/5%/10Kohm)		CRJ10DJ103T	
R465	nsp	RES, CHIP(1608/5%/220ohm)		CRJ10DJ221T	
R466	nsp	RES, CHIP(1608/5%/2.2Kohm)		CRJ10DJ222T	
R467	nsp	RES, CHIP(1608/5%/22Kohm)		CRJ10DJ223T	
R469,470	nsp	RES, CHIP(1608/5%/47Kohm)		CRJ10DJ473T	
R471	nsp	RES, CHIP(1608/5%/1Kohm)		CRJ10DJ102T	
R473	nsp	RES, CHIP(1608/5%/0ohm)		CRJ10DJ0R0T	
R480	nsp	RES, CHIP(1608/5%/22Kohm)		CRJ10DJ223T	
R481	nsp	RES, CHIP(1608/5%/100Kohm)		CRJ10DJ104T	
R483-488	nsp	RES, CHIP(1608/5%/20Kohm)		CRJ10DJ203T	
R489	nsp	RES, CHIP(1608/5%/10Kohm)		CRJ10DJ103T	
R490	nsp	RES, CHIP(1608/5%/100Kohm)		CRJ10DJ104T	
R491	nsp	RES, CHIP(1608/5%/10Kohm)		CRJ10DJ103T	
R492,493	nsp	RES, CHIP(1608/5%/47Kohm)		CRJ10DJ473T	
R495-500	nsp	RES, CHIP(1608/5%/1Kohm)		CRJ10DJ102T	
R501	nsp	RES, CARBON(1/5W,100Kohm,J)		CRD20TJ104T	
R502	nsp	RES, CHIP(1608/5%/4.7Kohm)		CRJ10DJ472T	

Ref. No.	Part No.	Part Name	Remarks	Q'ty	New
R510	nsp	RES, CARBON(1/5W,10Kohm,J)		CRD20TJ103T	
R550	nsp	RES, CARBON(1/4W,4.7Kohm,J)		CRD25TJ472T	
R552	nsp	RES, CARBON(1/4W,47Kohm,J)		CRD25TJ473T	
R553	nsp	RES, CARBON(1/5W,4.7Kohm,J)		CRD20TJ472T	
R554	nsp	RES, CARBON(1/5W,47Kohm,J)		CRD20TJ473T	
R555	nsp	RES, CARBON(1/5W,4.7Kohm,J)		CRD20TJ472T	
R600,601	nsp	RES, CHIP(1608/5%/47ohm)		CRJ10DJ470T	
R602,603	nsp	RES, CHIP(1608/5%/1Kohm)		CRJ10DJ102T	
R604,605	nsp	RES, CARBON(1/5W,100Kohm,J)		CRD20TJ104T	
R710,711	nsp	RES, CHIP(1608/5%/0ohm)		CRJ10DJ0R0T	
R750	nsp	RES, CHIP(1608/5%/22Kohm)		CRJ10DJ223T	
R910	nsp	RES, CARBON(1/5W,10Kohm,J)		CRD20TJ103T	
VR31,32	943161100150D	RES SEMI FIXED(4.7K,B CURVE)		CVN1GE472B01T	*
CAPACITORS GROUP					
C101-104	nsp	CAP, CERAMIC(50V/100pF/K)		CCKT1H101KB	
C105,106	nsp	CAP, ELECT(50V/10uF)		CCEA1HH100T	
C109,110	nsp	CAP, ELECT(16V/220uF)		CCEA1CH221T	
C111,112	nsp	EOL item CAP, MYLAR(50V/6800pF/J)		HCQ11H682JZT	
C113,114	nsp	CAP, MYLAR(50V/0.018pF/J)		HCQ11H183JZT	
C115,116	nsp	EOL item CAP, MYLAR(50V/6800pF/J)		HCQ11H682JZT	
C117,118	nsp	CAP, ELECT(50V/10uF)		CCEA1HH100T	
C119,120	nsp	CAP, MYLAR(50V/3900pF/J)		HCQ11H392JZT	
C121,122	00D2544569924	CAP, ELECT(ELNA, 6.3X11, RA3-25V 101MF3#8P-T2)		CCEA1ERA38P101T	
C215,216	00D2544702956	CAP, ELECT(ELNA,8X12,RFS-50V 100MG3#A-F1)		CCEA1HRFSA100E	
C220	nsp	CAP, ELECT(50V/22uF)		CCEA1HH220T	
C221	00D2544569924	CAP, ELECT(ELNA, 6.3X11, RA3-25V 101MF3#8P-T2)		CCEA1ERA38P101T	
C223	00D2544569924	CAP, ELECT(ELNA, 6.3X11, RA3-25V 101MF3#8P-T2)		CCEA1ERA38P101T	
C224	nsp	CAP, CHIP(1608, 50V/10pF)		CCUS1H100JA	
C225	nsp	CAP, ELECT(50V/10uF)		CCEA1HH100T	
C230	nsp	CAP, CHIP(1608, 50V/1000pF)		CCUS1H102KC	
C251	nsp	CAP, ELECT(50V/33uF)		CCEA1HH330T	
C252	nsp	CAP, CHIP(1608, 50V/0.022uF)		CCUS1H223KC	
C254	nsp	CAP, CHIP(1608, 50V/0.047uF)		CCUS1H473KC	
C256	nsp	CAP, ELECT(25V/47uF)		CCEA1EH470T	
C258	943134006150S	CAP, ELECT(10V/470uF),8X11.5L,RA3,ELNA		CCEA1ARA38P471T	
C303,304	nsp	CAP, CERAMIC(50V/470pF/K)		CCKT1H471KB	
C305,306	nsp	CAP, CERAMIC(50V/100pF/K)		CCKT1H101KB	
C307,308	nsp	CAP, CERAMIC(50V/1000pF/K)		CCKT1H102KB	
C309-312	00D2544774719	CAP, ELECT (220uF/25V,12.5X20, ELNA RFS)		CCEA1ERFSA221E	
C319-322	nsp	CAP, MYLAR(50V/2200pF/J)		HCQ11H222JZT	
C325,326	nsp	CAP, CERAMIC(50V/22pF/J)		CCCT1H220JC	
C327,328	nsp	CAP, CERAMIC(50V/1000pF/K)		CCKT1H102KB	
C329,330	00D2544703751	CAP, ELECT(ELNA, 10X12.5, RFS-50V 220MH3#A-F)		CCEA1HRFSA220E	
C331	nsp	CAP, CERAMIC(50V/0.01uF/K)		CCKT1H103KB	
C340	nsp	CAP, POLYESTER FILM(SEORYONG,PPF A 224 J 100V)		CCMP2A224JR11T	
C341,342	nsp	CAP, CERAMIC(50V/33pF/J)		CCCT1H330JC	
C346	nsp	CAP, CERAMIC(50V/0.01uF/K)		CCKT1H103KB	
C347	nsp	CAP, POLYESTER FILM(SEORYONG,PPF A 224 J 100V)		CCMP2A224JR11T	
C367	nsp	CAP, ELECT(50V/4.7uF)		CCEA1HH4R7T	
C375-378	nsp	CAP, MYLAR(50V/0.01uF/J)		HCQ11H103JZT	
C379,380	nsp	CAP, MYLAR(50V/0.1uF/J)		HCQ11H104JZT	
C390-392	nsp	CAP, MYLAR(50V/1000pF/J)		HCQ11H102JZT	
C394-396	nsp	CAP, MYLAR(50V/0.015uF/J)		CCQ11H153JZT	
C401	nsp	CAP, ELECT(16V/100uF)		CCEA1CH101T	
C402	nsp	CAP, CHIP(1608, 50V/0.01uF)		CCUS1H103KC	
C403	nsp	CAP, ELECT(16V/100uF)		CCEA1CH101T	

Ref. No.	Part No.	Part Name	Remarks	Q'ty	New
C404	nsp	CAP, CHIP(1608, 50V/0.01uF)		CCUS1H103KC	
C405	nsp	CAP, ELECT(16V/3300uF)		CCEA1CH332E	
C406	nsp	CAP, ELECT(50V/22uF)		CCEA1HH220T	
C407,408	nsp	CAP, CHIP(1608, 50V/0.01uF)		CCUS1H103KC	
C421	nsp	CAP, ELECT(50V/10uF)		CCEA1HH100T	
C445	nsp	CAP, CHIP(1608, 50V/0.1uF)		CCUS1H104KC	
C458	nsp	CAP, ELECT(50V/2.2uF)		CCEA1HH2R2T	
C461	nsp	CAP, CHIP(1608, 50V/0.01uF)		CCUS1H103KC	
C464	nsp	CAP, ELECT(50V/1uF)		CCEA1HH1R0T	
C465	nsp	CAP, ELECT(50V/10uF)		CCEA1HH100T	
C466	nsp	CAP, ELECT(10V/470uF)		CCEA1AH471T	
C486-489	nsp	CAP, CHIP(1608, 50V/0.01uF)		CCUS1H103KC	
C492	nsp	CAP, CHIP(1608, 50V/0.047uF)		CCUS1H473KC	
C493	nsp	CAP, ELECT(25V/47uF)		CCEA1EH470T	
C494,495	nsp	CAP, ELECT(50V/10uF)		CCEA1HH100T	
C500	nsp	CAP, ELECT(50V/2.2uF)		CCEA1HH2R2T	
C600,601	nsp	CAP, ELECT(50V/10uF)		CCEA1HH100T	
C901,902	00D9430189408	CAP, ELECT ELNA LAO SERIES 8200uF/56V		CCET56VLAO822N	
C903,904	nsp	CAP, METAL PE FILM(250V/0.1uF)		KCME2E104JP04T	
C907,908	00D2544702956	CAP, ELECT(ELNA,8X12,RFS-50V 100MG3#A-F1)		CCEA1HRFSA100E	
C909,910	00D2544664706	CAP, ELECT(ELNA, 12.5X25, RFS-63V 101MI6#A-F)		CCEA1JRFSA101E	
C921,922	nsp	CAP, CERAMIC 0.01uF 50V Z		CCFT1H103ZF	
C923	nsp	CAP, ELECT(25V/1000uF)		CCEA1EH102E	
C925-928	nsp	CAP, CERAMIC 0.01uF 50V Z		CCFT1H103ZF	
C929,930	00D2544703777	CAP, ELECT (47uF/50V,10X16, ELNA RFS)		CCEA1HRFSA470T	
OTHERS PARTS GROUP					
CN31,32	nsp	WAFER/STRAIGHT/2.5mm/3P		CJP03GA01ZY	
CN41	nsp	WAFER, STRAIGHT(DVD LOADER)		CJP06GA19ZY	
CN50	nsp	LOCKING TYPE, STRAIGHT WAFER, 2MM		CJP13GI236ZW	
CN51	nsp	LOCKING TYPE, STRAIGHT WAFER, 2MM		CJP07GI236ZW	
CN52	nsp	LOCKING TYPE, STRAIGHT WAFER, 2.5MM		CJP07GI237ZW	
CN53	nsp	LOCKING TYPE, STRAIGHT WAFER, 2MM		CJP09GI236ZW	
CN58	nsp	LOCKING TYPE, STRAIGHT WAFER (2mm)		CJP11GI236ZW	
CN93	nsp	LOCKING TYPE, STRAIGHT WAFER, 2.5MM		CJP03GI237ZW	
CN95	nsp	WAFER,YW396-03B(3.96mm)		CJP03GA90ZY	
⚠ F801-804	90M-FS001520R	FUSE(1A, 372 SERIES/TR5)		KBA2D1000A3EYT	
JK11	00D9430191700	2P JACK, IN/OUT		CJJ4N034Z	
JK21,22	943643101860D	RCA, JACK BOARD (WWW/RRR,6P)		CJJ4R058Z	*
JK41	943646100620S	2P SP TERMINAL BLACK/RED		CJJ5N022Z	*
JK51	943646100630S	2P SP TERMINAL RED/BLACK		CJJ5N021Z	*
L101,102	00D9430193601	COIL, TOROIDAL		CLU9S004Z	
RY31	943682000810S	RELAY,BC3-12H,DC12V,2C2P		CSL4A016ZU	
RY33	00D9430195006	RELAY,G5PA-28-MC,DC12V,2C1P		CSL3A018ZE	
RY51,52	943682000810S	RELAY,BC3-12H,DC12V,2C2P		CSL4A016ZU	
TH51	00D9430194502	THERMISTOR ASS'Y(170MM)		CRT0217025MM	
X401	nsp	RESONATOR, CERAMIC (8Mhz,15pF)		CVFCSTLS8M00G53A0T	
	00D9430194609	POSISTOR		CRTPTFM04BB222Q	
	00D2631100018	I.C,REGULATOR(+6V,T0220IS)		HVIKIA7806API	
	nsp	HEAT SINK		CMY2A138	